



Green Energy EPC by Makello, Inc. welcomes you to be informed about “*Installing Energy Independence*”™

## About the State of California Required Attachments:

The State of California requires us to attach certain disclosures and guides to our contract. In as much as these can contain potential confusions or ambiguities we provide this guide and cover sheet by way of explanation. You will find there are 3 State of California required documents in this package in addition to our contract as follows:

- 1) CALIFORNIA SOLAR CONSUMER PROTECTION GUIDE (Version 4, published 10/2025)
- 2) SOLAR ENERGY SYSTEM SUPPORTING INFORMATION
- 3) SOLAR ENERGY SYSTEM DISCLOSURE DOCUMENT and the actual Green Energy EPC by Makello, Inc. contract

The State of California requires that you go through these preliminary steps before signing the contract which is the final document in this package.

## Explanations of Required State Attachments:

- 1) CALIFORNIA SOLAR CONSUMER PROTECTION GUIDE, Example: Version 4, published 10/2025:



### California Solar Consumer Protection Guide

Published October 2025



The document “CALIFORNIA SOLAR CONSUMER PROTECTION GUIDE” is intended as a guide to

the complete process of buying a photovoltaic system. You could have received a copy of this earlier, if so, this is a duplicate. On page 4 it has the contractors licence information although this information is also part of the contract. If applicable, a Home Improvement Sales license is included.

You are required to read and initial page 3, and check every box on pages 6 and 7, and sign and date page 7, before signing a solar contract, as preparation for signing the actual solar contract.

2) SOLAR+ENERGY+SYSTEM+SUPPORTING+INFORMATION+V2, Example, published 11/1/2025:

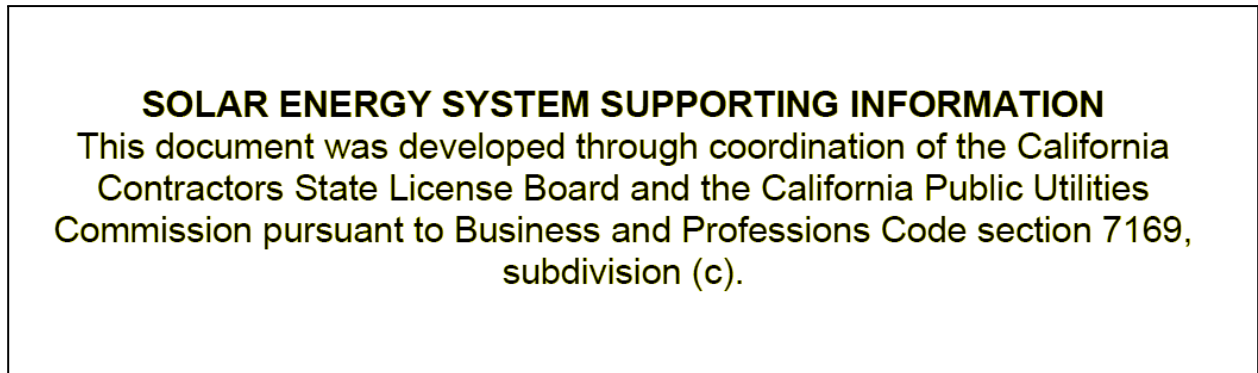

The final State of California required document the “SOLAR ENERGY SYSTEM SUPPORTING INFORMATION” mostly duplicates information from the contract or collects supporting information for statistical purposes. Because it simplifies some issues for uniformity of data collection some of the sections ask questions that do not necessarily have simple answers. To avoid ambiguity these are explained here:

- a) Section 1 boxes 1 and 3 of this document correctly says we shall not collect payment for materials not delivered. For clarity option 1 on our contract allows you to purchase the materials early to avoid tariff increases or future shortages. If you take this option and do not wish to take delivery to your site of the materials prior to installation you have the option to have them stored in a warehouse until they are installed. For purposes of this section such storage shall be considered delivery.
- b) Section 2 of this document has a check box asking will subcontractors be used to perform this work. This question is insufficiently detailed. Subcontractors may be used for parts of the job, for instance for roofing or plumbing work, so it is not a yes or no question. In any case as stated on page 2 of the contract our warranty covers all work whether or not it is performed by subcontractors.
- c) Section 4 of this document ENERGY SAVINGS has a box asking for Battery Minimum State of Charge. This is something that you can select and/or change so the figure shown here should be considered an initial value only. Also be aware that if you received incentives to purchase the battery the incentive program may impose limitations on this setting.
- d) Subsection 1 of section 4 asks for “Estimated Bill Savings for Systems with Solar and Battery Storage” and asks for the tool used to calculate the savings under several different scenarios. These savings will depend strongly on utility rates which can change. Further, you should be aware that the commercially available tools do not necessarily know every variant

of every utility rate so these should be considered good faith estimates. The same caveats apply with respect to bill savings depending on rates in subsection 2.

3) SOLAR ENERGY SYSTEM DISCLOSURE DOCUMENT and the actual Green Energy EPC by Makello, Inc. contract:

- a) The first required document the “SOLAR ENERGY SYSTEM DISCLOSURE DOCUMENT” is a simple one page statement of your rights. It includes the total price of the system and notifies you of your right to cancel within 5 days, it was added by the State of California to protect consumers from high pressure sales tactics.

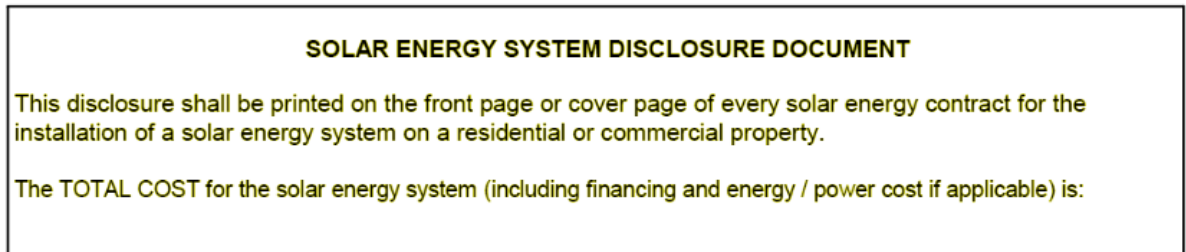

- b) The actual Green Energy EPC by Makello, Inc. contract. Example, published 02/2026:

 <p><b>Green Energy EPC by Makello Inc.</b>  <b>A Solar Electric Company</b>          California C-10 Electrical License #1110498          INSURED - BONDED - CERTIFIED - WORKER'S COMP          9434 Chesapeake Dr, Suite 1210, San Diego, CA 92123  <a href="https://www.yelp.com/biz/green-energy-epc-san-diego">https://www.yelp.com/biz/green-energy-epc-san-diego</a></p> <p>Laurence Crispin, Electrician / Lead Installer, 619-599-2580, <a href="mailto:laurence@greenepc.com">laurence@greenepc.com</a>          Jeremy Magana, Project Manager, Electrical, 619-599-2585, <a href="mailto:jeremy@greenepc.com">jeremy@greenepc.com</a>          Michelle Hitchcock, Administrative / Invoicing, 619-599-2584, <a href="mailto:michelle@greenepc.com">michelle@greenepc.com</a>          Charlie Johnson, President, 858-833-2465, <a href="mailto:charlie@greenepc.com">charlie@greenepc.com</a></p>	kW DC Solar Photovoltaic System
	<p><b>Solar PV Proposal</b>          Electric System</p> <p>Notice: Under California law, you have the right to receive a notification of lien rights. This means that if you do not pay for the solar equipment or services, the contractor may have the right to place a lien on your property. It is important to understand your rights and obligations under this contract. Visit <a href="https://cslb.ca.gov/">https://cslb.ca.gov/</a></p>

(end of “Explanations of Required State of California Attachments v5a 20260302.pdf”)



# California Solar Consumer Protection Guide

**Putting solar panels and/or batteries on your home is an important financial decision. Don't sign a contract until you read and sign this document!**

This guide is from the California Public Utilities Commission (CPUC), a government agency that regulates utility companies like Pacific Gas and Electric Company, Southern California Edison Company, San Diego Gas & Electric Company, Liberty Utilities, Bear Valley Electric Service, and PacifiCorp.

Customers of the companies mentioned above must sign this guide to connect a residential solar system to the electric grid. The CPUC requires these companies to collect your signed copy of this guide to ensure that you know your rights and have enough information to make a decision.

## Guide Accessibility

Audio recording available at 855-955-1535.

Español, 中文, 한국어, Tiếng Việt, Tagalog, Armenian, Portuguese, and Dari audio versions available at 866-849-8390.



### Learn more best practices for going solar.

View a longer version of the California Solar Consumer Protection Guide with even more information at [www.cpuc.ca.gov/solarguide](http://www.cpuc.ca.gov/solarguide). Or use the camera on your mobile device to go to the link through the QR code below:

Published October 2025



If you think you have been a victim of solar fraud or have been denied any of the rights on the next page, you may file a complaint against a contractor or home improvement salesperson with the Contractors State License Board (CSLB) at 800-321-CSLB (2752) or [www.cslb.ca.gov/consumers](http://www.cslb.ca.gov/consumers).

If you think you've been a victim of financial fraud, visit [www.dfpi.ca.gov/file-a-complaint](http://www.dfpi.ca.gov/file-a-complaint).

# Know Your Rights

## You have the right...

### **...to read this entire guide before signing a contract.**

The CPUC recommends that solar providers give out this guide during their first contact with potential customers. Do not feel pressured to read this guide while the salesperson waits. Ask them to come back at a later date to allow you time to read it.

### **...to a copy of a solar contract and financing agreement in the language in which the salesperson spoke to you.**

If a solar provider or salesperson comes to sell you solar panels and speaks to you in a language other than English, they must give you a copy of the contract in that language. Also, if you prefer to read this guide in Armenian, Chinese, Dari, Korean, Portuguese, Spanish, Tagalog, or Vietnamese, the solar provider or salesperson must give you this guide in that language.

### **...to a Solar Disclosure Document from your solar provider.**

By law, a solar provider must provide you with a completed Solar Energy System Disclosure Document created by the Contractors State License Board (CSLB). This document shows you the total costs for the solar energy system and other important financial information. A blank version of this document is available at [cslb.ca.gov/consumers/solar\\_smart](https://www.cslb.ca.gov/consumers/solar_smart).

### **...to a 3-day cancellation period after signing a contract.**

You have at least three business days to cancel your contract for any reason, or 5 days if you are 65 or older. You may cancel the contract by emailing, mailing, faxing, or delivering a notice to your solar provider by midnight of the third business day after you received a signed, dated copy of the contract. Note that different rules may apply for contracts negotiated at a company's place of business.

# Watch Out for False Claims

Most solar providers are honest and fair. However, if a salesperson makes one of these false claims to you, do not do business with them.

## False Claim      The Truth

---

**You can get free solar energy at no cost to you.**

**Solar energy is rarely free. An honest company will be upfront about all the costs you will pay over time.** There may be some exceptions for qualifying low-income homeowners and residential properties taking part in the Disadvantaged Communities – Single family Solar Homes (DAC-SASH) program for income-qualified homeowners in disadvantaged communities, or the Self-Generation Incentive Program (SGIP). Go to [www.cpuc.ca.gov/solarguide/lowincomesolar](http://www.cpuc.ca.gov/solarguide/lowincomesolar) to see if you qualify.

---

**You will never pay an electricity bill again after a solar system is installed.**

**Going solar reduces, but does not eliminate, your monthly utility bill.** Customers who take out a solar loan or sign a lease or power purchase agreement will also receive a monthly bill from a loan company or solar provider.

---

**You must sign now to get solar.**

**An honest salesperson would never rush you to sign anything without giving you time to review what you are signing.** California law requires that a salesperson show you the contract terms before you sign. Read everything carefully! You are also legally entitled to ask to sign a paper copy of this document with a wet signature.

---

**You can take advantage of solar business tax credits if you register yourself as an LLC.**

**Getting solar or storage on a residential property means you won't qualify for business tax credits.** Anybody telling you to start a limited liability company (LLC) to go solar is trying to convince you to do something illegal and you shouldn't do business with them.

---

**Customer Initials:** \_\_\_\_\_



If you think you have been a victim of solar fraud or have been denied any of the rights on the next page, you may file a complaint against a contractor or home improvement salesperson with the Contractors State License Board (CSLB) at 800-321-CSLB (2752) or [www.cslb.ca.gov/consumers](http://www.cslb.ca.gov/consumers).

If you think you've been a victim of financial fraud, visit [www.dfpi.ca.gov/file-a-complaint](http://www.dfpi.ca.gov/file-a-complaint).



## Before You Sign a Contract

**Make sure to get bids from at least 3 different solar providers.** Look up how to compare quotes online and compare the bids you've obtained. Note that the cheapest bid is not necessarily the best option for you. A very low bid may indicate that a solar provider is trying to cut corners. **Don't hesitate to ask any solar provider questions.**

**Ask for the solar provider's CSLB license number.** If you were contacted by a telephone or door-to-door salesperson, ask for their individual home improvement salesperson (HIS) registration number. Check the number(s) to make sure they are valid and associated with the solar provider by going to [www.cslb.ca.gov/consumers](http://www.cslb.ca.gov/consumers) or calling 800-321-CSLB (2752).

CSLB License Number is: \_\_\_\_\_ 1110498 \_\_\_\_\_

(If applicable)

HIS Registration Number is: \_\_\_\_\_ 89771 SP \_\_\_\_\_

The CSLB license must be active and should hold license classification(s) C-46 (Solar Contractor), C-10 (Electrical Contractor), and/or B (General Building Contractor) in order to install a residential solar energy system.

# “Before You Sign” Checklist

**Make sure you have completed these items before you sign any documents!**

**Do not sign anything if you feel you need more time to do research or think about your decision.**

- Get at least 3 bids for solar at your home.
- Carefully read all the other documents that the solar provider provides you. These at minimum should include: 1) Solar Energy System Disclosure Document, 2) contract, and 3) financial paperwork.
- Check to see if you qualify for any low-income solar programs at [cpuc.ca.gov/solarguide/lowincomesolar](http://cpuc.ca.gov/solarguide/lowincomesolar) which have strong protections for consumers.
- Consider making your home more energy efficient before getting solar. This could save you money and be more affordable than installing solar.
- Visit the CPUC Solar Consumer Protection Guide website, [www.cpuc.ca.gov/solarguide](http://www.cpuc.ca.gov/solarguide), for more information on what to look for in a good provider and how to protect yourself against fraud.
- Ask the solar provider for 3 customer references and call or visit them.
- Check to make sure the solar provider’s license, and if applicable, the home improvement salesperson’s registration number, is current and valid with the Contractors State License Board at: [www.cslb.ca.gov/onlineservices/checklicenseii/checklicense.aspx](http://www.cslb.ca.gov/onlineservices/checklicenseii/checklicense.aspx)
- Understand the timeline of what happens after you sign a contract for solar.
- If you are getting battery storage with your solar system, make sure you understand the different settings your battery can be set at to fit your financial and energy goals. Have your installer walk through the different options if you haven’t.
- Understand how your electricity bill will work once you install solar or a battery. Ask your installer and/or your utility company to explain it to you.
- Check to see if your solar provider is listed on the CPUC’s Public List of Non-Compliant Solar Providers at: [www.cpuc.ca.gov/solarpubliclist](http://www.cpuc.ca.gov/solarpubliclist)
- If you are financing your system through a third party, ask the lender, solar provider, or program administrator to explain the financing arrangement. Find a list of important questions to ask at [www.cpuc.ca.gov/solarguide](http://www.cpuc.ca.gov/solarguide)
- Save copies of all the documents you receive. This includes downloading a hard copy of your documents to your computer, or even printing them out. The information will be useful if you sell your home, need to replace your roof, or have any repair or maintenance issues.

# Sign This Guide

Do not feel pressured to read all your documents while the salesperson waits.

You can ask them to come back at a later date to allow you time to read your contract and this guide before you sign. Please affirm each of the statements below by initialing each line. If a statement does not apply to you, write “N/A” instead. Each box **MUST** contain your initials or “N/A.” Keep track of any questions you have.

## Customer

Please affirm each of the statements below by checking each box. If a statement does not apply to you, write “N/A” in that statement’s box. Each box **MUST** be checked or contain an “N/A.”

- I have not yet entered into a contract for solar with the solar provider signing.
- The solar provider provided me with a copy of this 7-page Solar Consumer Protection Guide before they collected my signature below.
- The solar provider gave me the time to read this entire 7-page guide and visit the CPUC’s online Solar Consumer Protection Guide ([www.cpuc.ca.gov/solarguide](http://www.cpuc.ca.gov/solarguide)).
- I was provided an option to sign this Solar Consumer Protection Guide electronically or in handwriting if I requested.
- If I was solicited as part of a door-to-door sale and did not expressly request an electronic format, a copy of the Solar Consumer Protection Guide was provided in paper format.
- The solar provider gave me the opportunity to read this guide in Spanish, Chinese, Korean, Vietnamese, Tagalog, Armenian, Portuguese, or Dari if they spoke to me in one of those languages.
- If I choose to sign the Solar Consumer Protection Guide electronically, I am using an email address that was created and controlled by me prior to the sale, lease, or power purchase agreement.
- I have received a Solar Energy System Disclosure Document, which lists the financial details of my solar and or/battery system.
- In Section 4 “Energy Savings” of the Solar Energy System Disclosure Document, if the solar provider was not able to use my one-hour interval electric consumption data, the solar provider has given me a satisfactory explanation as to why, and I attest that they made a reasonable effort to access this data.
- I understand that any estimate I receive on my potential electricity bill savings not contained in the Solar Energy System Disclosure Document was calculated using the

average electricity rate escalation calculated by the CPUC, at most. I can find this maximum average at [www.cpuc.ca.gov/solarguide](http://www.cpuc.ca.gov/solarguide), and can ask my installer what rate was used at any time.

- I have asked my contractor for an explanation of any bill savings estimate I received.
- The solar provider has explained and provided me documentation on the finances of this installation, including how much I am paying now, how much I will be paying each month, and how any interest or escalation rates will affect my payments in the future.

By signing, I affirm that I have read and understand the California Solar Consumer Protection Guide. I also affirm that information from my solar contract, interconnection application, Solar Energy System Disclosure Document, and/or financing agreement may be reviewed and collected by state regulators to ensure compliance with California’s solar consumer protection laws.

\_\_\_\_\_  
Customer Printed Name

\_\_\_\_\_  
Date

\_\_\_\_\_  
Customer Signature

## Solar Provider

Charlie Q Johnson, President  
Company Representative Name

04/20/2026  
Date

\_\_\_\_\_  
Representative Signature

858-833-2465  
Company Phone

Green Energy EPC by Makello, Inc  
Company Name

charlie@greenepc.com  
Company Email

1110498  
CSLB License Number

C-10  
Company CSLB License Classification

## **SOLAR ENERGY SYSTEM SUPPORTING INFORMATION**

This document was developed through coordination of the California Contractors State License Board and the California Public Utilities Commission pursuant to Business and Professions Code section 7169, subdivision (c).

## **1. IMPORTANT INFORMATION FOR CONSUMER**

**Except for a limited down payment, it is against the law for a contractor to collect payment for work not yet completed, or for materials not yet delivered.**

**This is true whether the payment comes from you or your financing company/lender.**

**If there is a down payment, it cannot exceed the lesser of \$1,000 or 10 percent of the contract price.**

**If you are asked to make payment(s) before the project is completed, please be aware it is against the law for a contractor to collect payment for work not yet completed, or for materials not yet delivered.**

**Be careful about payments for “plans” or “permits” before the work starts. Call or go to your local permitting office’s website to confirm permit costs before paying them.**

**If you are asked to make payments and are not provided with a payment schedule or believe the contractor requested or accepted payment that exceeds the value of the work performed or material delivered, file a complaint with CSLB.**

**Unscrupulous salespeople may offer false incentives, rebates, or other offers to pressure you into signing a solar contract. Do your own research to make sure incentives, rebates, or other offers by a contractor are legitimate.**

**You have three days to review or cancel any agreement before you commit to it, or five days if you are over 65 unless this sale was negotiated at a contractor’s place of business. Review the following pages carefully.**

## 2. INSTALLATION INFORMATION

**Will subcontractors be used to perform this work?  Yes  No**

*If yes, the Contractor will provide me the name, license information, and contact information for all subcontractors before installation begins.*

**Information about warranty coverage is in the contract on page: 2 - 3**

**Make sure the system is permitted and inspected. Systems not installed to code can cause problems. Solar systems also may need maintenance; mechanical, electrical, software, and internet problems can occur.**

**Information about the service and maintenance of the system is in the contract on page: 2 - 3**

## 3. INFORMATION ABOUT THE AGREEMENT

### PPAs/Leases:

**Is this a power purchase agreement (PPA)/Lease?  Yes  No.**

**Customer will not own system. For PPAs, customer will pay for the power the system uses. For leases, customers will pay to use the system)**

Name of financing company: \_\_\_\_\_

Term of PPA/Lease: \_\_\_\_\_ years \_\_\_\_\_ months

**Can the customer transfer the system to a new homeowner if they want to sell their house?  Yes  No.** This may require the customer to pay off the agreement in full. See page(s) \_\_\_\_\_ of the contract for more information.

### Financing:

**Is this a purchase? (Customer will own system)  Yes  No.**

**Is the contractor facilitating a solar loan for the customer?  Yes  No.**

If PACE financing is used, the customer will receive a separate disclosure document.

Name of financing company: \_\_\_\_\_

Term of loan: \_\_\_\_\_ years \_\_\_\_\_ months

## Complete One:

### 1. CASH/LOAN:

Total cost for the solar energy system or purchase, including installation fees, document preparation fees, service fees or other fees before subtracting possible rebates or tax credits.

\$ 25,983.94

*NOTE: You may or may not be eligible for federal tax credits or state/federal incentives. See [www.cpuc.ca.gov/solarguide](http://www.cpuc.ca.gov/solarguide) or consult your tax or legal professional for further information.*

Monthly payment (loans only):

\$ \_\_\_\_\_

Interest rate (loans only):

\_\_\_\_\_ %

### 2. LEASE:

Total Cost:

\$ \_\_\_\_\_

Monthly payment:

\$ \_\_\_\_\_

Escalator\*:

\_\_\_\_\_ % per year

### 3. PPA:

Energy rate for power purchase agreement:

\_\_\_\_\_ \$/kWh

Escalator\*:

\_\_\_\_\_ % per year

Upfront payment, if applicable

\$ \_\_\_\_\_

Monthly payments, if applicable

\$ \_\_\_\_\_

Go to [www.cpuc.ca.gov/solarguide](http://www.cpuc.ca.gov/solarguide) for more information on each of these fees.

\* An escalator is a price increase over time. Ask your provider to explain how much your bills are expected to increase every year due to an escalator, and why they are including an escalator.

## 4. ENERGY SAVINGS

**When designing your solar or solar + storage system, companies will give you an estimate of how much you will save on your electricity bill. This section shows this estimated bill savings. The estimate can be used as a guide, but is not a guarantee of future savings, which will depend on many factors. Go to [www.cpuc.ca.gov/solarguide](http://www.cpuc.ca.gov/solarguide) to learn more about protecting yourself from misleading claims and other useful things to know before you sign a contract.**

### Inputs and Assumptions\*

My Annual Electricity Usage (*past 12 months*\*\*)

0 kWh

Estimated Annual Solar Electricity Generation (estimation of *what my system will generate*) \*\*\*

2,080 kWh

Battery Capacity

10 kWh

Battery Minimum State of Charge

25 %

**Before:** Electricity provider's rate schedule you are on now

*Before*

**After:** Electricity provider's eligible rate schedule after installation

*After*

**\*\*If 12 months of data not available, explain why and how usage was determined here:**

--

**Your contractor must provide one of the two required estimates that follow, based on whether your planned system will have a battery or not.**

**1. Estimated Bill Savings for Systems with Solar and Battery Storage:**

***Required Estimate: Battery optimized for maximizing bill savings (battery is programmed to optimize bill savings by serving onsite load or exporting to the grid based on price signals)***

<u>Required Calculation</u>	Total Estimated Savings in First Year \$ 1,324.75
-----------------------------	--

***Optional Estimate: Battery programmed to prioritize self-consumption (battery prioritizes offsetting electricity use over discharging to the grid)***

<u>Optional Calculation</u>	Total Estimated Savings in First Year \$
-----------------------------	---

***Optional Estimate: Battery programmed for home back-up (prioritize keeping battery charged in case of outages)***

<u>Optional Calculation</u>	Total Estimated Savings in First Year \$
-----------------------------	---

**Name of Calculator Used:**

Potential Annual Utility Savings = ( 2,080 kWhs NREL PV Watts Estimated Annual Solar Production * Average Utility Electric \$0.4/kWh ) + (10 kWhs Battery Capacity * 75% D.O.D. * 90% round-trip efficiency * 365 days * 50% utilization * \$0.4/kWh) = \$1,324.75.
--

## 2. Estimated Bill Savings for Systems with Solar Only (no battery):

<u>Required calculation***</u>	Total Estimated Savings in First Year \$
--------------------------------	---

Name of Calculator Used:

*\*Explanation and criteria for the standardized inputs and assumptions are available here:*

<https://docs.cpuc.ca.gov/PublishedDocs/Published/G000/M344/K976/344976563.PDF>. Beginning in late 2025 and 2026, rates charged to all customers (meaning customers without rooftop solar and with rooftop solar) will include a base services charge to fairly recover costs from all customers for electric grid infrastructure and other shared costs. Please see [https://www.cpuc.ca.gov/-/media/cpuc-website/divisions/energy-division/documents/demand-response/demand-flexibility-oir/ab205\\_factsheet\\_050824.pdf](https://www.cpuc.ca.gov/-/media/cpuc-website/divisions/energy-division/documents/demand-response/demand-flexibility-oir/ab205_factsheet_050824.pdf) for more information. Calculations are to be made with an assumption of no rate escalation. Go to [www.cpuc.ca.gov/solarguide](http://www.cpuc.ca.gov/solarguide) for the current average annual escalation rate of electricity costs.

*\*\*\*Estimates of the solar-only portion of installations must use calculations based on PVWatts (available at <https://pvwatts.nrel.gov/>) to calculate annual solar electricity generation, pursuant to Resolution E-5364.*

Non-sensitive information contained in this document may be disclosed publicly for industry transparency and evaluation purposes. No personally identifiable data will be published and any information disclosed will be done in accordance with applicable privacy law and policies.

## **SOLAR ENERGY SYSTEM DISCLOSURE DOCUMENT**

This disclosure shall be printed on the front page or cover page of every solar energy contract for the installation of a solar energy system on a residential or commercial property.

The TOTAL COST for the solar energy system (including financing and energy / power cost if applicable), subject to adjustment as described elsewhere in this Contract, is: \$25,983.94

To make a complaint against a contractor who installs this system and/or the home improvement salesperson who sold this system, contact the Contractors State License Board (CSLB) through their website at [www.cslb.ca.gov](http://www.cslb.ca.gov) (search: "complaint form"), by telephone at 800-321-CSLB (2752), or by writing to P.O. Box 26000, Sacramento, CA 95826.

If the attached contract was not negotiated at the contractor's place of business, you have a Five-Day Right to Cancel the contract, pursuant to Business and Professions Code (BPC) section 7159, as noted below. For further details on canceling the contract, see the Notice of Cancellation, which must be included in your contract.

### **Five-Day Right to Cancel**

You, the buyer, have the right to cancel this contract within five business days. You may cancel by e-mailing, mailing, faxing, or delivering a written notice to the contractor at the contractor's place of business by midnight of the fifth business day after you received a signed and dated copy of the contract that includes this notice. Include your name, your address, and the date you received the signed copy of the contract and this notice.

This document was developed through coordination of the California Contractors State License Board and the California Public Utilities Commission pursuant to Business and Professions Code section 7169.



**Green Energy EPC by Makello Inc.**  
**A Solar Electric Company**

California C-10 Electrical License #1110498  
**HOME IMPROVEMENT CONTRACT**

INSURED - BONDED - CERTIFIED - WORKER'S COMP  
 9434 Chesapeake Dr, Suite 1210, San Diego, CA 92123

<https://www.yelp.com/biz/green-energy-epc-san-diego>

Laurence Crispin, Electrician / Lead Installer, 619-599-2580, [laurence@greenepc.com](mailto:laurence@greenepc.com)  
 Jeremy Magana, Project Manager, Electrical, 619-599-2585, [jeremy@greenepc.com](mailto:jeremy@greenepc.com)  
 Michelle Hitchcock, Administrative / Invoicing, 619-599-2584, [michelle@greenepc.com](mailto:michelle@greenepc.com)  
 Charlie Johnson, President, 858-833-2465, [charlie@greenepc.com](mailto:charlie@greenepc.com)

**1.305kW DC Solar Photovoltaic System**  
**10kWh/7.08kW LiFePO4 Energy Storage**

**Solar PV & Battery Proposal**  
 Electric System

Notice: Under California law, you have the right to receive a notification of lien rights. This means that if you do not pay for the solar equipment or services, the contractor may have the right to place a lien on your property. It is important to understand your rights and obligations under this contract. Visit <https://cslb.ca.gov/>

**Customer Name & Address:**

**Name:**  
**Phone:**  
**Email:**  
**Account#:**

**Parcel Number:**  
**Authority Having Jurisdiction:**

**Utility Electric Meter#:**

**System Description**

APPROXIMATE START DATE:04/28/2026

APPROXIMATE COMPLETION DATE:07/27/2026

- **1.305kW** DC PV Electric System Roof and 10kWh/7.08kW Charge/Discharge Enphase Energy IQBATTERY-10C-1P-NA LiFePO4 Energy Storage.
  - **System shall be designed with:** 3 x Hyundai Energy Solutions TOPCon or Hanwha QCELLS Q.TRON 435w - 440w w/25 years performance warranty\*.
  - **System shall be designed with:** 3 x Enphase IQ8PLUS-72-2-US Inverter(s) that carry 25 Years Warranty.
  - The system shall have high quality racking and mounting system and BOS (Balance of System, all hardware).
  - The system shall meet NEC (National Electric Code) and local AHJ (Authority having Jurisdiction) standards.
  - Will install additional grounding if required.
  - The system shall have network monitoring to document commissioned equipment use, energy production, and if applicable, storage & consumption.
  - **System shall be designed with:** 1 x Enphase Energy IQBATTERY-10C-1P-NA: 10kWh/7.08kW LiFePO4 Energy Storage with 15 Years Warranty.
- \* Exact module wattage will depend upon availability at install time. Any change will be discussed with customer.

Extra Work and Change Orders become part of the contract once the order is prepared in writing and signed by the parties prior to the commencement of any work covered by the new change order. The order must describe the scope of the extra work or change, the cost to be added or subtracted from the contract, and the effect the order will have on the schedule of progress payments.

**Green Energy EPC by Makello, Inc. Scope of Work**

1. Design the solar electric photovoltaic and/or battery system
2. Obtain applicable permits, perform load calculation, and schedule post installation Inspection.
3. Install system components as described.
4. Schedule post installation inspection.
5. Coordinate with utility company to make grid inter-connection.
6. Commission the system and configure monitoring.
7. Facilitate client with applicable rebate and incentives paperwork.

## Warranties, Terms and Conditions

1. Solar & Battery Workmanship: carries a warranty of ten (10) years from date of completion.
2. Green Energy EPC by Makello, Inc. will facilitate with individual component manufacturer's warranties.
3. The system will be completed within reasonable industry standard timelines.
4. Green Energy EPC by Makello, Inc. will setup system monitoring.
5. It is the System Owner's responsibility to monitor the function and power production of the system.
6. Green Energy EPC by Makello, Inc. is not liable if the system shuts off due to any reason. We shall fix and repair the system when notified by system owner within the warranty period.

## \* Special Notes

1. The system price covers designing, engineering, permit, equipment, installation, labor and utility interconnection application only.
2. Any unforeseen conditions will be additional charge to the customer.
3. Any modifications, changes, change orders or necessary upgrades to the existing electrical system or building structure will change the total cost of the proposed system. This will be discussed with the customer and will be additional charge to the customer.
4. **Includes:**
  - **Utility Interconnection and permit application fee(s), and processing.**
  - **SGIP, RSSE and/or SDCP battery rebate application processing. (Value \$995)**
  - **Up to 10' of battery conduit with wiring length 20' total @ \$25/ft , to the nearest Meter or Panel location. (Value \$500)**
  - **Optional monitoring:** Install monitoring on the circuits serving spaces designated by the client. Install a subpanel or reroute circuits as necessary to isolate the designated spaces. Install a model ¶ **TBD, See Below** monitoring system with internet reporting capability and record keeping features.
  - **Energy Storage for electrical panel(s) 200A maximum busbar rating:**
    - NOT every load of the house can be backed up. Only essential lighting, and essential appliances.
    - Some ACs, electric resistance water heaters, space heaters and dryers, motors, pumps, EV Fast Charging and other big loads are NOT backed up.
    - Existing Main Electric panel shall meet Code Requirement in Ampacity and Voltage requirements.
    - Panel and Service upgrade may be required. To be determined by our qualified site evaluator.
    - If necessary, Electric Panel Upgrade is extra \$3,750 in-place, or \$4,250 relocated. Estimated 2 months minimum or more for Disconnect/Reconnect order.
    - Qualifies for Federal Tax Credit as it is part of a solar-battery project.
  - **Enphase Meter Collar, Combiner, Gateway, Current Transformers. If necessary, Controller, Load Shed, Comms Kit 2, Envoy S-Meter.**
5. Electric System Change: (Assumes existing panel qualifies for solar. If necessary, trenching is extra cost.)
  - New 8' ground rod(s) will be installed as required by the AHJ, in absence of Ufer Ground, using #4 wire.
  - Cold water pipe bonding as required by the AHJ, in absence of Ufer Ground, using #4 wire.
  - Wall patch and/or conduit will be done by the contractor. Owner to provide wall paint or matching color paint. Contractor will paint.
  - This cost is eligible for a Federal Income Tax Credit. Customer pays for trenching & underground conduit, TBD, if required by Utility.
6. Will subcontractors be used to perform this work? [ ] Yes [ ] No  
If Yes is checked: One or more subcontractors will be used on this project, and the contractor is aware that a list of subcontractors is required to be provided, upon request, along with the names, contact information, license number, and classification of those subcontractors.

¶ For additional monitoring at the identified locations, if it proves necessary to modify the electrical system or site, by relocating and isolating circuits, or if it's necessary to install a subpanel, then a Change Order will be issued after the final site inspection.

<b>Gross System Cost:</b>	<b>\$25,984</b>
Estimated Federal Tax Credit 48E & Depreciation 78% * 25% Business Use: <b>Qualified minimum 5% Safe Harbor Payment by 7/4/26 to build by 2030; otherwise 2027.</b>	-\$4,937
Self Generation Incentive Program and/or San Diego Community Power rebate(s): (Up To, Waitlisted, Not Guaranteed; Depends on Funding, Enrollment, Qualifications)	-\$1,250
<b>Net System Cost (After Qualified Incentives, As Low As*):</b>	<b>\$19,797</b>
All pricing is limited to 2 (two) weeks from the date the contract is generated: 2026-04-20 04:24 PM PDT	
Gross Cost does NOT include: a) HOA application or architectural review fees; b) construction costs to repair, replace, or relocate existing equipment, if it is necessary to improve site condition before install.	



**Internal Accounting, Form Inputs and Values:**

160 kWhs/Month electric use --= 1.305 kW DC solar PV annual production.

**Solar Per Watt Adders**

Base Solar Cost Per Watt:	\$5.97/w
Z-Rack: None:	\$0.00/w
Site Type: Roof	\$0.00/w
Roof Type: Composite Shingle / Metal seam (standing)	\$0.00/w
Site Adders: No Site Adder Selected	\$0.00/w
Complexity: Easy	\$0.00/w
Steep: N/A	\$0.00/w
Custom	\$0.00/w
-----	
Total Solar Per Watt Adders:	\$5.97/w
Solar Photovoltaic System watts:	x 1,305 watts
Subtotal Solar Cost:	\$7,790.85

**Flat Fee Adders**

Makello Admin, Document, Design, Analyze, Qualify Incentives:	\$1,394.75
Solar Design Included in Basic System:	-\$295.00
Alumni Discount:	-\$500.00
Main Service Panel: No Change	\$0.00
Change of Order: No Change of Order:	\$0.00
NEM1 / NEM2 / NBT, and Internal Processing Fee:	\$282.00
Z-Rack: None	\$0.00
Battery: 1 x Enphase 10C; 10kWh/7.08kW:	\$18,611.34
Battery Positioning Fee: Exterior Wall	\$0.00
Custom: Alumni Promo: \$1,300 Off Solar - Battery 2026	-\$1,300.00
Install Months:3. Adder = (3 - 3) * 0.5% = 0.0%	\$0.00
-----	
Subtotal Flat Fee Adders:	\$18,193.09
Subtotal Solar Cost (From the table on the left):	\$7,790.85
-----	
Total Gross Cost:	\$25,983.94

This automatic pricing tool uses a ratio of 1,600 kWh / kW DC of solar PV, to determine the solar system size. Some locations may have different shading, DC to AC Size Ratio, and System Losses, and thus, a different NREL PVWatts Estimate. Green Energy EPC by Makello will provide a revised NREL PVWatts Estimate based on the actual site conditions. If the system size requires an adjustment to meet or surpass the electric monthly average kWh goal, then the contract will be revised and reissued at a new Gross Cost, requiring countersignature approval.

**Estimated Financial Incentives:**

50% Federal Tax Credit, and 28% Depreciation for a qualified Business Use solar or solar-battery system, at a Residential property.  
**\*Any Estimated Tax Credit is an estimate only and should NOT be relied on as tax advice. A qualified tax advisor should be consulted to accurately assess and qualify business use and your eligibility for tax credits. We are not tax experts.**

**Modular 5P or 10C Batteries**



**Progress Payments: DOWNPAYMENT MAY NOT EXCEED \$1,000 OR 10 PERCENT OF THE CONTRACT PRICE, WHICHEVER IS LESS.**

1) Down payment at time of signing the contract: .....	\$ 1,000.00	
2) After design, engineering, and applications submittal (permit, interconnection, and if applicable, HOA, rebate):.....	\$ 2,884.00	Checksum:
a) Material costs are also due at this time if Option 1 is selected below, in the "MATERIAL" section.		Solar/Electric & Permit(s): \$8,167.60
b) Any advance payment amounts received will reduce the amount due on the subsequent Progress Payment(s).		Battery/Electric & Permit(s): \$18,611.34
3) After confirmed delivery (or warehouse receipt per Option 1) of solar modules, inverters, and battery equipment:.....	\$ 14,364.97	Alumni Discount: -\$500.00
4) After significant installation and system can be turned on and/or commissioned: .....	\$ 6,624.99	Solar Design Discount: -\$295.00
5) Final amount due after inspection, monitoring and interconnection: .....	\$ 1,109.98	<b>\$25,983.94</b>
6) Overdue amounts may incur a 1.25% per month fee, based on the date the funds are received.	<b>Total: \$ 25,983.94</b>	

<u>Location / # Modules</u>	<u>Orientation &amp; Access</u>	<u>Up to kWh/Yr, NREL PV Watts Production Estimate</u>	<u>Up to kWh/Module/Yr</u>
* In the best solar access area(s), TBD: <span style="border: 1px solid black; padding: 2px;">3</span>	180 Azimuth, 18 Tilt, 18.18% Losses (Default): <input checked="" type="checkbox"/>	<span style="border: 1px solid black; padding: 2px;">2,080</span> kWh/Year (1st Yr)	<span style="border: 1px solid black; padding: 2px;">693</span> kWh/Module/Yr

(Using an average San Diego, CA ratio for solar production estimate: 1,600kWhs / kW DC. See NREL PVWatts Example after "Additional Terms and Conditions".)

1 THIS CONTRACT IS SUBJECT TO THE ADDITIONAL TERMS AND CONDITIONS AS SET FORTH IN THE ATTACHED, WHICH IS INCORPORATED HEREIN. THE UNDERSIGNED ACKNOWLEDGES RECEIPT OF A TRUE COPY OF THIS CONTRACT, INCLUDING THE ADDITIONAL TERMS AND CONDITIONS, ACKNOWLEDGES THAT HE/SHE HAS READ AND KNOWS THE CONTENTS HEREOF, AND UNDERSTANDS THAT NO OTHER AGREEMENT OR REPRESENTATIONS BY THE AGENT, EITHER VERBAL OR OTHERWISE, IS BINDING UPON THE PARTIES HERETO, AND THAT THE TRUE COPY OF THIS CONTRACT CONTAINS THE ENTIRE AGREEMENT.

The schedule of progress payments must specifically describe each phase of work, along with the amount of each proposed progress payment. IT IS AGAINST THE LAW FOR A CONTRACTOR TO COLLECT PAYMENT FOR WORK NOT YET COMPLETED, OR FOR MATERIALS NOT YET DELIVERED. HOWEVER, A CONTRACTOR MAY REQUIRE A DOWNPAYMENT.

**Due to cost of MATERIALS marketplace uncertainty, such as solar panels, inverters and batteries, material costs will be billed separately from labor costs. The Customer has 2 Options for paying material costs below:**

**Option 1:** Is to pay the full costs of material for the job described in this Contract when the Design is approved by Customer to be submitted to the Authority Having Jurisdiction, in which case the Contractor bears the risk of any increase in the cost of materials.

**Option 2:** Deferred Material Payment: Owner elects NOT to pay material costs at design approval. Owner acknowledges that if material costs increase after permit approval due to tariff changes, supply disruption, or other market factors, Contractor shall document the cost increase and issue a written Change Order specifying the exact amount of increase. No additional material cost may be charged to Owner without a signed Change Order. Owner's right to cancel this Contract within the statutory cancellation period is not affected by selection of either Option 1 or Option 2, and any downpayment received shall be returned within 10 days of a valid cancellation notice regardless of which option is selected.

Contact CSLB: 9821 Business Park Drive, Sacramento, CA 95827

Non-payment of contracted monies is subject to a Mechanic's Lien.

You are entitled to a completely filled in copy of this agreement, signed by both you and the contractor, before any work may be started.

<p><b>For</b></p> <p><b>Green Energy EPC by Makello Inc.</b></p> <p><b>Charlie Q Johnson, President</b></p> <p>_____</p> <p style="text-align: center;">Green Energy EPC by Makello Inc. Signature and Date</p>	<p><b>Customer Acceptance<sup>1</sup></b></p> <p>_____</p> <p style="text-align: center;">Customer Signature, Name and Date</p>
---	---

Click below, or Copy/Paste this link into a web browser, to make a secure \$1,000 Down Payment by ACH (No Fee!)

<https://connect.intuit.com/pay/GreenEnergyEPCbyMakelloInc/scs-v1-008ced9e44784500891858191378456792cb3128ad9c47bd82ca357ea3389827798a585f84574d5faec7f3f868efc930>

**Use ACH, get a FREE Peshtemal Beach Towel: Full length, lightweight, compact, sand resistant weave. Water & energy efficient. Up to 15 towels per large washer!**

Click below, or Copy/Paste this link into a web browser, to make a secure \$1,000 Down Payment by Debit Card, Credit Card or Apple Pay. (No Fee!)

<https://connect.intuit.com/pay/GreenEnergyEPCbyMakelloInc/scs-v1-91ed614ef7b94836ba4da99f0450c58e4908160b9ff6489b97df579c146dcbb14394184a95594c179ae5fc6f22215b47>

Click below, or Copy/Paste the link into a web browser, to make a secure \$1,000 Down Payment by PayPal or Venmo (No Fee!):

<https://connect.intuit.com/pay/GreenEnergyEPCbyMakelloInc/scs-v1-d5eff1b63f2e48e9ab56fa69c9fdf7345bc3b66e04594b918a5c99ae5a77a76883dea20b6b4a46489cc1a5f2ff0eaeef6>

ADDITIONAL TERMS AND CONDITIONS (Customer Contract.v10 20260406)

1. The Contractor makes no guarantees, representations, or warranties regarding system output, or production, expected utility rate increases, or any other factors used to calculate the Customer's payments or savings. No production estimates, whether given verbally or in writing, shall be legally binding, and are merely intended as informational estimates.
2. In the event the system is not installed **due to no fault** of the Contractor within 2 months after the later of (a) the date the permit is issued or (b) the date the utility interconnection application is accepted (the "Approval Date"), the Contractor shall have the right to renegotiate the pricing of the system. If the parties are unable to reach agreement on a new contract price, either party shall have the right to terminate the contract upon advance written notice to the other party. Upon cancellation by either party, the Contractor shall have the right to keep the deposit and invoice the Customer for services rendered that are in excess of the payments received to date. Upon payment of any such invoices, the Contractor shall provide the Customer with the work product, designs and documentation upon request.
3. To the fullest extent permitted by law, the Customer shall indemnify, defend, protect, save and hold harmless the Contractor and its employees, officers, directors, agents, successors, members, and assigns (the "Indemnified Parties") from any and all third party claims, actions, costs, expenses, including reasonable attorneys' fees and expenses, damages, liabilities, penalties, losses, obligations, injuries, demands and liens of any kind or nature arising out of, connected with, relating to or resulting from (i) the Customer's negligence or willful misconduct, violation of law, breach of this Contract or any misrepresentation by the Customer hereunder (each a "Claim"); provided, that nothing herein shall require the Customer to indemnify any Indemnified Party to the extent a Claim results from such Indemnified Party's own negligence or willful misconduct or (ii) the existence, uncovering or unveiling, or any release of any hazardous or toxic substance, waste or material, or any other substance, pollutant or condition that poses a risk to human health or the environment at the Customers home. The provisions of this Section shall survive termination or expiration of this Contract.
4. (a) NO CONSEQUENTIAL DAMAGES. NEITHER PARTY SHALL BE LIABLE TO THE OTHER PARTY FOR CONSEQUENTIAL, INCIDENTAL, PUNITIVE, EXEMPLARY, SPECIAL OR INDIRECT DAMAGES.  
  
(b) ADDITIONAL LIMITATION OF LIABILITY. THE TOTAL LIABILITY UNDER THIS CONTRACT SHALL IN NO EVENT EXCEED (i) IN THE CASE OF THE CONTRACTOR, THE PORTION OF THE CONTRACT PRICE ACTUALLY RECEIVED BY THE CONTRACTOR AND (ii) IN THE CASE OF THE CUSTOMER, THE CONTRACT PRICE.  
  
(c) IMPLIED WARRANTIES. TO THE EXTENT THERE ARE ANY STATUTORILY REQUIRED IMPLIED WARRANTIES, INCLUDING THE IMPLIED WARRANTIES OF FITNESS FOR A PARTICULAR PURPOSE AND MERCHANTABILITY, SUCH WARRANTIES, TO THE EXTENT PERMITTED BY APPLICABLE LAW, SHALL IN NO EVENT EXTEND PAST THE EXPIRATION OF ANY WARRANTY PERIOD IN THIS CONTRACT. TO THE EXTENT SUCH WARRANTIES ARE NOT STATUTORILY REQUIRED, THE CONTRACTOR MAKES NO SUCH WARRANTIES UNDER THIS CONTRACT.
5. The terms of this Contract are intended by the parties as the exclusive, complete and final expression of their Contract with respect to such terms and may not be contradicted by evidence of any prior or contemporaneous Contract. This Contract specifically supersedes any prior written or oral agreements between the parties with respect to the subject matter of this Contract.

6. When a solar system produces electricity, the system is eligible to receive Renewable Energy Certificates (REC). If you purchase your solar system, you own any RECs created. If you enter a lease or PPA, ask your solar provider who will own the RECs, and check the contract fine print. Solar system owners may sell the RECs they generate. System owners would need to qualify for the Western Renewable Energy Generation Information System (WREGIS), which issues and tracks RECs. Please visit [wecc.org/program-areas/wregis](http://wecc.org/program-areas/wregis) for more information.
7. Your solar system may also be eligible to participate in a Virtual Power Plant (VPP) program. Check with your local energy provider or other supplier for available programs or search "Virtual Power Plant California" in your favorite web browser.
8. If the performance of this Contract, or any obligation hereunder except the making of payments hereunder is prevented, restricted, or interfered with by reason of: terrorism, fire, flood, earthquake, explosion, or other casualty or accident; inclement weather that makes compliance with applicable OSHA work requirements unfeasible; strikes or labor disputes; inability to procure or obtain delivery of parts, supplies, or power; war or other violence; pandemic or any other act or condition whatsoever beyond the reasonable control of the affected party, the party so affected, upon giving prompt notice to the other party, will be excused from such performance to the extent of such prevention, restriction, or interference; provided that the party so affected will take all reasonable steps to avoid or remove such cause of non-performance and will resume performance hereunder with dispatch whenever such causes are removed.
9. The invalidity of any portion of this Contract will not and shall not be deemed to affect the validity of any other provision. If any provision of this Contract is held to be invalid, the parties agree, the remaining provision shall be deemed to be in full force and effect, as if they had been executed by both parties, subsequent to the expungement of the invalid provision.
10. The failure of either party to this Contract to insist upon the performance of any of the terms and conditions of this Contract, or the waiver of any breach of any of the terms and conditions of this Contract, shall not be construed as subsequently waiving any such terms and conditions, but the same shall continue and remain in full force and effect, as if no such forbearance or waiver had occurred.
11. IN THE EVENT A DISPUTE BETWEEN THE PARTIES RELATING TO THIS CONTRACT IS UNRESOLVED AFTER THIRTY (30) DAYS OF WRITTEN NOTICE OF THE DISPUTE FROM ONE PARTY TO THE OTHER PARTY, THE PARTIES HEREBY AGREE TO SUBMIT THE UNRESOLVED MATTER TO MEDIATION. MEDIATION SHALL OCCUR IN SAN DIEGO COUNTY, CALIFORNIA. THE COST OF THE MEDIATOR SHALL BE BORNE EQUALLY BY THE PARTIES.

IN THE EVENT OF ANY DISPUTE, CONTROVERSY OR CLAIM ARISING OUT OF, OR RELATING TO, THIS CONTRACT IS UNRESOLVED BY MEDIATION, THE PARTIES SHALL SUBMIT THE MATTER TO BINDING ARBITRATION BEFORE A SINGLE, NEUTRAL ARBITRATOR. SUCH ARBITRATION SHALL BE GOVERNED BY AND CONDUCTED THROUGH THE AMERICAN ARBITRATION ASSOCIATION OR OTHER MUTUALLY AGREEABLE ARBITRATION GROUP. THE ARBITRATION HEARING SHALL BE HELD IN SAN DIEGO COUNTY, CALIFORNIA, AT A PLACE TO BE DESIGNATED BY MUTUAL AGREEMENT OF THE PARTIES OR, IN THE ABSENCE OF THEIR AGREEMENT, BY THE ARBITRATOR.

NOTICE: BY INITIALING IN THE SPACE BELOW YOU ARE AGREEING TO HAVE ANY DISPUTE ARISING OUT OF THE MATTERS INCLUDED IN THE 'ARBITRATION OF DISPUTES' PROVISION DECIDED BY NEUTRAL ARBITRATION AS PROVIDED BY CALIFORNIA LAW AND YOU ARE GIVING UP ANY RIGHTS YOU MIGHT POSSESS TO HAVE THE DISPUTE LITIGATED IN A COURT OR JURY TRIAL. BY INITIALING IN THE SPACE BELOW YOU ARE GIVING UP YOUR JUDICIAL RIGHTS TO DISCOVERY AND APPEAL, UNLESS THOSE RIGHTS ARE SPECIFICALLY INCLUDED IN THE 'ARBITRATION OF DISPUTES' PROVISION. IF YOU REFUSE TO SUBMIT TO

ARBITRATION AFTER AGREEING TO THIS PROVISION, YOU MAY BE COMPELLED TO ARBITRATE UNDER THE AUTHORITY OF THE BUSINESS AND PROFESSIONS CODE OR OTHER APPLICABLE LAWS. YOUR AGREEMENT TO THIS ARBITRATION PROVISION IS VOLUNTARY. WE HAVE READ AND UNDERSTAND THE FOREGOING AND AGREE TO SUBMIT DISPUTES ARISING OUT OF THE MATTERS INCLUDED IN THE ARBITRATION OF DISPUTES PROVISION TO NEUTRAL ARBITRATION. Owner Initials: \_\_\_\_\_ Contractor Initials: \_\_\_\_\_

12. Exclusive Venue

For any litigation, action, or proceeding arising from or relating to this Contract that is not subject to or resolved through arbitration under §11, the parties agree that exclusive venue shall lie in the Superior Court of San Diego County, California. Each party expressly waives any right to contest such venue.

13. Note About Extra Work and Change Orders.

Extra Work and Change Orders become part of the contract once the order is prepared in writing and signed by the parties prior to the commencement of work covered by the new change order. The order must describe the scope of the extra work or change, the cost to be added or subtracted from the contract, and the effect the order will have on the schedule of progress payments.

Customer may not require the Contractor to perform extra or change-order work without providing written authorization prior to the commencement of work covered by the new change order.

Extra work or a change order is not enforceable against the Customer unless the change order also identifies all of the following in writing prior to the commencement of work covered by the new change order:

- (i) The scope of work encompassed by the order.
- (ii) The amount to be added or subtracted from the contract.
- (iii) The effect the order will make in the progress payments or the completion date.

The Contractor's failure to comply with the requirements of this paragraph does not preclude the recovery of compensation for work performed based upon legal or equitable remedies designed to prevent unjust enrichment.

14. Commercial General Liability Insurance (CGL).

The Contractor carries commercial general liability insurance written by Underwrites at Lloyd's, London. You may call Underwrites at Lloyd's, London: 408-212-0499 to check the Contractor's insurance coverage.

15. Workers' Compensation Insurance.

The Contractor carries workers' compensation insurance for all employees.

16. MECHANICS LIEN WARNING:

Anyone who helps improve your property, but who is not paid, may record what is called a mechanics lien on your property. A mechanics lien is a claim, like a mortgage or home equity loan, made against your property and recorded with the county recorder.

Even if you pay your contractor in full, unpaid subcontractors, suppliers, and laborers who helped to improve your property may record mechanics liens and sue you in court to foreclose the lien. If a court

finds the lien is valid, you could be forced to pay twice or have a court officer sell your home to pay the lien. Liens can also affect your credit.

To preserve their right to record a lien, each subcontractor and material supplier must provide you with a document called a 'Preliminary Notice.' This notice is not a lien. The purpose of the notice is to let you know that the person who sends you the notice has the right to record a lien on your property if they are not paid.

**BE CAREFUL.** The Preliminary Notice can be sent up to 20 days after the subcontractor starts work or the supplier provides material. This can be a big problem if you pay your contractor before you have received the Preliminary Notices.

You will not get Preliminary Notices from your prime contractor or from laborers who work on your project. The law assumes that you already know they are improving your property.

**PROTECT YOURSELF FROM LIENS.** You can protect yourself from liens by getting a list from your contractor of all the subcontractors and material suppliers that work on your project. Find out from your contractor when these subcontractors started work and when these suppliers delivered goods or materials. Then wait 20 days, paying attention to the Preliminary Notices you receive.

**PAY WITH JOINT CHECKS.** One way to protect yourself is to pay with a joint check. When your contractor tells you it is time to pay for the work of a subcontractor or supplier who has provided you with a Preliminary Notice, write a joint check payable to both the contractor and the subcontractor or material supplier.

For other ways to prevent liens, visit CSLB's internet website at [www.cslb.ca.gov](http://www.cslb.ca.gov) or call CSLB at 800-321-CSLB (2752).

**REMEMBER, IF YOU DO NOTHING, YOU RISK HAVING A LIEN PLACED ON YOUR PROPERTY.** This can mean that you may have to pay twice, or face the forced sale of your property to pay what you owe.

Upon satisfactory payment being made for any portion of the work performed, the contractor, prior to any further payment being made, shall furnish the Customer a full and unconditional release from any potential lien claimant claim or mechanics lien authorized pursuant to Sections 8400 and 8404 of the Civil Code for that portion of the work for which payment has been made.

17. Information about the Contractors State License Board (CSLB): CSLB is the state consumer protection agency that licenses and regulates construction contractors.

Contact CSLB for information about the licensed contractor you are considering, including information about disclosable complaints, disciplinary actions, and civil judgments that are reported to CSLB.

Use only licensed contractors. If you file a complaint against a licensed contractor within the legal deadline (usually four years), CSLB has authority to investigate the complaint. If you use an unlicensed contractor, CSLB may not be able to help you resolve your complaint. Your only remedy may be in civil court, and you may be liable for damages arising out of any injuries to the unlicensed contractor or the unlicensed contractor's employees.

For more information:

Visit CSLB's internet website at [www.cslb.ca.gov](http://www.cslb.ca.gov)

Call CSLB at 800-321-CSLB (2752)

Write CSLB at P.O. Box 26000, Sacramento, CA 95826.

18. Right to Stop Work.

Contractor shall have the right on 48 hours written notice to the Owner to stop the Work if any payment shall not be made to Contractor when earned and payable under this Contract. Contractor may keep the job idle until all payments due are received, and may, on an additional 48 hours written notice, permanently terminate performance under this Contract. If Contractor elects to demobilize as a result of Owner's failure to pay, Contractor shall be entitled to a change order for reasonable costs associated with remobilization.

19. Termination for Convenience by Owner.

The owner may, at any time, for any reason, terminate this Contract by delivering written notice to the Contractor identifying the termination date. Upon termination after commencement of Work, Contractor shall be entitled to: (a) all amounts due but not yet paid; (b) direct costs of supplies, materials, or equipment specifically purchased for this project; (c) costs under non-cancelable supplier agreements; (d) any reasonable loss on materials resold below purchase price; and (e) reasonable direct costs of demobilization. The contractor shall not be paid for loss of anticipated profits. Compensation shall not exceed the unpaid balance of the Contract Price. Termination for Cause by Contractor. Contractor may terminate this Contract for cause if the Owner's payment of any invoice is more than thirty (30) days overdue. Upon such termination, the Contractor shall be entitled to the same compensation as described in Termination for Convenience above.

20. Statutory Bond Notice

You have the right to require the Contractor to carry a performance and payment bond for the Work. Notwithstanding this statutory notice, Contractor is not obligated to provide a performance or payment bond and may refuse to provide them.

21. Exclusions from Work and Contract Price:

Unless specifically included in the scope of work above or added by a signed Change Order, this Contract does not include labor, materials, or costs for: a) Additional work required by governmental plan checkers on final Red-Lined plans. b) Moving the owner's personal property around the site. c) Labor or materials required to repair or replace any Owner-supplied materials. d) Repair of concealed underground utilities not located on prints or physically staked out by the owner which are damaged during construction. e) HOA application, architectural review, or approval fees. f) Repair of damage to roadways, driveways, or sidewalks from construction equipment during normal operations. g) Cost of correcting errors and omissions by Owner's design professionals or separate contractors. h) Cost of correcting, testing, or remediating mold, fungus, mildew, or organic pathogens unless caused by sole and active negligence of Contractor as a direct result of a construction defect causing sudden and significant water infiltration. i) Electric panel upgrade, if required [see Special Notes for estimated cost]. j) Trenching or underground conduit, if required by utility. k) Concrete footing for battery, if required.

Owner acknowledges receipt of and agreement with these Exclusions:

Owner Initials: \_\_\_\_\_ Date: \_\_\_\_\_

22. Roof Tiles and Disclosure Regarding Tile Matching

If a dwelling's roof is not to be replaced by Contractor or another licensed contractor, Owner acknowledges that not all roofing tiles can be re-used and an exact matching of existing roof tiling may not be possible. Owner agrees that in the event that Contractor is unable to identically match roof tiles, Contractor reserves the right to use replacement tiles with similar aesthetics.

23. Concealed or Unknown Physical Conditions

If concealed or unknown physical conditions, hazardous materials, or other unforeseen conditions are encountered during the Work, that differ materially from those indicated in or from those conditions ordinarily found to exist, Contractor shall be entitled to a change order. Unforeseen conditions include dry rot and termite damage, as these cannot be observed until the existing roof is removed.

24. Pre-Existing Issues, Defects, or Code Violations

Unless expressly stated in the Work (including change orders), Contractor shall not be obligated to or responsible for identifying any pre-existing unforeseen conditions, defects, or code violations. Nor shall Contractor be liable for pre-existing issues, defects, or code violations discovered after completion of the Work.

25. MARKETING RELEASE

Owner, as legal owner of the property at the project address, grants to Green Energy EPC by Makello, Inc., its employees, and marketing agents, the right to take and use photographs, video, aerial photographs (including drone footage), and other media of the Property for advertising, trade, or any commercial purpose. Contractor shall not disclose Owner's personal information (name, address) in connection with such use without Owner's separate written consent.

Owner Signature: \_\_\_\_\_ Date: \_\_\_\_\_

26. NOTICE OF CANCELLATION

2026-04-20  
(Date)

You may cancel this transaction, without any penalty or obligation, within five business days from the above date.

If you cancel, any property traded in, any payments made by you under the contract or sale, and any negotiable instrument executed by you will be returned within 10 days following receipt by the seller of your cancellation notice, and any security interest arising out of the transaction will be canceled.

If you cancel, you must make available to the seller at your residence, in substantially as good condition as when received, any goods delivered to you under this contract or sale, or you may, if you wish, comply with the instructions of the seller regarding the return shipment of the goods at the seller's expense and risk.

If you do make the goods available to the seller and the seller does not pick them up within 20 days of the date of your notice of cancellation, you may retain or dispose of the goods without any further obligation. If you fail to make the goods available to the seller, or if you agree to return the goods to the seller and fail to do so, then you remain liable for performance of all obligations under the contract."

To cancel this transaction, mail or deliver a signed and dated copy of this cancellation notice, or any other written notice, or send an email to Green Energy EPC by Makello, Inc. by any of the following methods: • Mail or deliver: 9434 Chesapeake Dr., Suite #1210, San Diego, CA 92123 • Email: info@greenepc.com • Phone (for assistance completing this form): (619) 599-2585. Cancellation is effective upon sending by any of the above methods by midnight of the cancellation deadline. not later than midnight of 2026-04-27. For assistance, call/text 619-599-2585. (Allow 24 hours for response.)

I hereby cancel this transaction. \_\_\_\_\_ . (Date)

\_\_\_\_\_  
(Buyer's signature, and Full Name)

**ADDITIONAL DISCLOSURES for Green Energy EPC by Makello solar or solar-battery upgrades**

Name: \_\_\_\_\_,

Address: \_\_\_\_\_, Date: 04/20/2026

(Customer to initial in each space below, if applicable, to acknowledge disclosure of relevant information)

Meter Collar Integration of Battery:

\_\_\_\_\_ The Meter Collar is utility approved for use with battery integration, and for whole house backup power. During a utility outage, if home appliance loads are greater than the solar-battery system output, the meter collar can automatically switch off only one load control circuit. If after switching off the one load controlled circuit, the appliance loads are still greater than the power output of the solar-battery system, then the solar-battery system will shut down automatically and attempt to restart a few minutes later.

Therefore, in advance of a power outage, it is the Customer's responsibility to select appliance(s) to be shed automatically during a utility power outage, and if there is more than one circuit for high load appliances, hire an electrician to move those circuits to a new 'load shed' subpanel, at extra cost.

During a power outage, it is the Customer's responsibility to shut off major appliances to reduce loads to be within the battery output limit, and to monitor battery capacity on the monitoring App, and to be judicious about running appliance loads, to save capacity in case of longer utility outages, or for expectations of low solar production weather or seasonality.

After a power outage, the Customer can decide to increase battery capacity and output, within the limits of the electrical equipment manufacturer specifications, or to relocate circuits to a load shed subpanel.

Micro-grid Capability Timeline:

\_\_\_\_\_ Legacy Enphase M-Series solar microinverters are currently incapable of forming a micro-grid for off-grid battery charging. The manufacturer update is expected soon. In the period before the product update(s), when the utility power grid is ON, the Enphase 10C or 5P batteries are charged from legacy M-Series solar power and optionally from utility power. After the Enphase updates are completed, the batteries will be charged by legacy M-Series solar, even when the utility grid is OFF.

\_\_\_\_\_ Grid-tied non-Enphase solar inverters are not currently supported by Enphase for off-grid battery charging during a utility power outage. In the period before the firmware and/or software update for non-Enphase inverter micro-grid support, when the utility power grid is ON, the Enphase 10C or Enphase 5P batteries are charged from compatible Enphase microinverters, and the Non-Enphase solar inverter through the Meter Collar aggregator circuit. After the Enphase firmware and software updates are completed, the batteries can be charged by non-Enphase solar inverters when the utility grid is OFF.

Incentives Timeline:

\_\_\_\_\_ After the system installation is complete, it is customary to call for a next available inspection. However, if the application for solar or battery rebate(s) is not approved or reserved, then the Customer may wish to delay an inspection date, in which case the system is OFF, and the utility will provide power at their regular rate. The Customer is responsible for paying all utility costs for utility service, regardless of whether the solar or solar-battery system is OFF or ON, or whether or not the system is working.

Incentives Timeline: (continued)

\_\_\_\_\_ A reason to delay inspection is to avoid inadvertently losing a rebate. If a solar or battery system receives Permission To Operate before a rebate approval, the rebate is disqualified. Some jurisdictions automatically notify a utility after passing final inspection, and some have an ability to hold utility notification, however, the Company is not responsible for the Authority Having Jurisdiction's timeline or accuracy.

\_\_\_\_\_ If an inspection is delayed at the Customer's request, the Customer is responsible for the potential consequences to the tax credit or rebate(s) incentives. For a system that is completed and expenditures made, but if the inspection is scheduled in the next calendar year, some tax experts have suggested that if the system passes inspection without correction, the system could be considered to be finished in the year completed for tax purposes. In the absence of a formal ruling from the IRS taxpayers should consult their tax adviser, in the situation described.

\_\_\_\_\_ A second, vacation, or rental home, or business use, may qualify for solar or battery 48E incentives.

If there is Business Use of a property, then the solar or solar-battery 48E Tax Credit may be up to:  
(30% Solar Tax Credit + 10% Domestic Content Bonus + 10% Energy Community Bonus) \* Business Use %

In addition, 100% Write-Off, Bonus Depreciation or MACRS Depreciation of equipment may apply to proportional percentage of Business Use.

"Business Use %" is calculated proportionally for residential properties, and can be determined by:

- Percentage of home office square footage ratio to total square footage of home, OR
- Percentage of measured total electric use (including Plug-In Vehicles or appliances for business use)

Business Use of a property can qualify the 48E tax incentive proportional to the fraction of business usage, but only if there is income tax from one of these sources:

- Self-employed individuals reporting business income on Schedule C
- Independent contractors
- Sole proprietors
- Single-member LLCs taxed as sole proprietorships
- Partners in partnerships (subject to specific rules)
- S-corporation shareholders (through accountable plan reimbursements from the corporation)

**IMPORTANT NOTE:**

Makello.com and Green Energy EPC by Makello, Inc. are NOT tax experts and the above is not tax advice. We cannot guarantee incentive acceptance, funds availability, and incentive amount. Consult your tax professional for more information on Business Use tax incentives for residential or commercial properties.

The National Renewable Energy Laboratory (NREL) "PV Watts" solar photovoltaic performance estimation tool results:



**RESULTS**

Based on the following sample inputs for San Diego, each kW DC of Solar PV can be expected to produce, in the 1st Year, up to:

**1,600 kWh/Year\***

*System output may range from 1,538 to 1,610 kWh per year near this location.*

*Click [HERE](#) for more information.*



Caution: Photovoltaic system predictions calculated by PVWatts many inherent assumptions and uncertainties and do not reflect between PV technologies nor characteristics except as represented by PVWatts® inputs. For example, with better performance differentiated within PVWatts® performing modules. Both NREL companies provide more sophisticated modeling tools (such as the Syst Model at <https://sam.nrel.gov>) for more precise and complex modeling systems.

The expected range is based on actual weather data at the given location and is intended to provide an indication of the variation you might see. For more information, please refer to the Error Report.

Disclaimer: The PVWatts® Model is provided by the National Renewable Energy Laboratory ("NREL"), operated by the Alliance for Sustainable Energy, LLC ("Alliance") for the Department of Energy ("DOE"). The Model shall not be used for any purpose whatsoever.

The names DOE/NREL/ALLIANCE shall not be used in any representation, publicity or other manner which endorses or promotes any entity or uses the Model. DOE/NREL shall not provide

any support, consulting, or assistance of any kind with regard to the use of the Model or any update or new versions of the Model.

YOU AGREE TO INDEMNIFY /ALLIANCE, AND ITS OFFICERS, AGENTS, AND EMPLOYEES AGAINST ANY CLAIM OR DAMAGES, INCLUDING REASONABLE ATTORNEY'S FEES, RELATED TO YOUR USE, OR ADOPTION OF THE MODEL FOR ANY PURPOSE WHATSOEVER. THE MODEL IS PROVIDED BY DOE/NREL/ALLIANCE AND ANY EXPRESS OR IMPLIED WARRANTIES, INCLUDING LIMITED TO THE IMPLIED WARRANTY OF MERCHANTABILITY AND FITNESS FOR A PARTICULAR PURPOSE ARE DISCLAIMED. IN NO EVENT SHALL DOE/NREL/ALLIANCE BE LIABLE FOR SPECIAL, INDIRECT OR CONSEQUENTIAL DAMAGES OR ANY DAMAGES WHATSOEVER, INCLUDING THE LOSS OF DATA OR PROFITS, FROM ANY A CONTRACT, NEGLIGENCE OR TORTIOUS CLAIM THAT ARISES IN CONNECTION WITH THE PERFORMANCE OF THE MODEL.

The energy output range is based on an analysis of 30 years of historical weather data for nearby locations, and is intended to provide an indication of the possible variability in generation for a typical PV system at this location.

Month	Solar Radiation ( kWh / m <sup>2</sup> / day )	AC Energy ( kWh )
January	4.62	108
February	5.09	106
March	5.92	131
April	6.94	146
May	6.69	145
June	7.51	157
July	7.42	160
August	7.45	159
September	6.83	143
October	5.78	129
November	4.95	111
December	4.45	105
<b>Annual</b>	<b>6.14</b>	<b>1,600</b>

**EXAMPLE: NREL PVWATTS Estimate 1st Year Solar Production above, based on inputs below:**

**Location and Station Identification**

Requested Location	9434 Chesapeake Dr., Suite #1210, San Diego, CA 92123
Weather Data Source	Lat, Lng: 32.85, -117.14 1.2 mi
Latitude	32.85° N
Longitude	117.14° W

**PV System Specifications**

DC System Size	1 kW
Module Type	Premium
Array Type	Fixed (roof mount)
System Losses	18.18%
Array Tilt	18°
Array Azimuth	180°
DC to AC Size Ratio	1.5172413793103448275862068965517
Inverter Efficiency	97%
Ground Coverage Ratio	0.4
Albedo	From weather file
Bifacial	No (0)

This automatic pricing tool uses a ratio of 1,600 kWh / kW DC of solar PV, to determine the solar system size. Some locations may have different shading, DC to AC Size Ratio, and System Losses, and thus, a different NREL PVWatts Estimate.

Green Energy EPC by Makello will provide a revised NREL PVWATTS Estimate based on the actual site conditions. If the system size requires an adjustment to meet or surpass the electric monthly average kWh goal, then the contract will be revised and reissued at a new Gross Cost, requiring countersignature approval.

Monthly Irradiance Loss	Jan	Feb	Mar	Apr	May	June
	0%	0%	0%	0%	0%	0%
Monthly Irradiance Loss	July	Aug	Sept	Oct	Nov	Dec
	0%	0%	0%	0%	0%	0%

**Performance Metrics**

DC Capacity Factor	18.3%
--------------------	-------



# IQ8 and IQ8+ Microinverters

Our newest IQ8 Microinverters are the industry’s first microgrid-forming, software defined microinverters with split-phase power conversion capability to convert DC power to AC power efficiently. The brain of the semiconductor-based microinverter is our proprietary application specific integrated circuit (ASIC) which enables the microinverter to operate in grid-tied or off-grid modes. This chip is built in advanced 55nm technology with high speed digital logic and has superfast response times to changing loads and grid events, alleviating constraints on battery sizing for home energy systems.



Part of the Enphase Energy System, IQ8 Series Microinverters integrate with the IQ Battery, IQ Gateway, and the Enphase App monitoring and analysis software.



IQ8 Series Microinverters redefine reliability standards with more than one million cumulative hours of power-on testing, enabling an industry-leading limited warranty of up to 25 years.



Connect PV modules quickly and easily to IQ8 Series Microinverters using the included Q-DCC-2 adapter cable with plug-n-play MC4 connectors.



IQ8 Series Microinverters are UL listed as PV Rapid Shutdown Equipment and conform with various regulations, when installed according to manufacturer’s instructions.

### Easy to install

- Lightweight and compact with plug-n-play connectors
- Power Line Communication (PLC) between components
- Faster installation with simple two-wire cabling

### High productivity and reliability

- Produce power even when the grid is down\*
- More than one million cumulative hours of testing
- Class II double-insulated enclosure
- Optimized for the latest high-powered PV modules

### Microgrid-forming

- Complies with the latest advanced grid support\*\*
- Remote automatic updates for the latest grid requirements
- Configurable to support a wide range of grid profiles
- Meets CA Rule 21 (UL 1741-SA) and IEEE 1547:2018 (UL 1741-SB)

### Note:

IQ8 Microinverters cannot be mixed together with previous generations of Enphase microinverters (IQ7 Series, IQ6 Series, etc) in the same system.

\*Only when installed with IQ System Controller 2, meets UL 1741.  
 \*\*IQ8 and IQ8Plus support split-phase, 240V installations only.

# IQ8 and IQ8+ Microinverters

INPUT DATA (DC)		IQ8-60-2-US	IQ8PLUS-72-2-US
Commonly used module pairings <sup>1</sup>	W	235 – 350	235 – 440
Module compatibility		60-cell / 120 half-cell	54-cell / 108 half-cell, 60-cell / 120 half-cell, 66-cell / 132 half-cell and 72-cell / 144 half-cell
MPPT voltage range	V	27 – 37	27 – 45
Operating range	V	16 – 48	16 – 58
Min. / Max. start voltage	V	22 / 48	22 / 58
Max. input DC voltage	V	50	60
Max. continuous input DC current	A	10	12
Max. input DC short-circuit current	A		25
Max. module I <sub>sc</sub>	A		20
Oversvoltage class DC port			II
DC port backfeed current	mA		0
PV array configuration		1 x 1 Ungrounded array; No additional DC side protection required; AC side protection requires max 20A per branch circuit	
OUTPUT DATA (AC)		IQ8-60-2-US	IQ8PLUS-72-2-US
Peak output power	VA	245	300
Max. continuous output power	VA	240	290
Nominal (L-L) voltage / range <sup>2</sup>	V	240 / 211 – 264	
Max. continuous output current	A	1.0	1.21
Nominal frequency	Hz	60	
Extended frequency range	Hz	47 – 68	
AC short circuit fault current over 3 cycles	Arms	2	
Max. units per 20 A (L-L) branch circuit <sup>3</sup>		16	13
Total harmonic distortion		<5%	
Oversvoltage class AC port		III	
AC port backfeed current	mA	30	
Power factor setting		1.0	
Grid-tied power factor (adjustable)		0.85 leading – 0.85 lagging	
Peak efficiency	%	97.7	
CEC weighted efficiency	%	97	
Night-time power consumption	mW	60	
MECHANICAL DATA			
Ambient temperature range		-40°C to +60°C (-40°F to +140°F)	
Relative humidity range		4% to 100% (condensing)	
DC Connector type		MC4	
Dimensions (H x W x D)		212 mm (8.3") x 175 mm (6.9") x 30.2 mm (1.2")	
Weight		1.08 kg (2.38 lbs)	
Cooling		Natural convection – no fans	
Approved for wet locations		Yes	
Pollution degree		PD3	
Enclosure		Class II double-insulated, corrosion resistant polymeric enclosure	
Environ. category / UV exposure rating		NEMA Type 6 / outdoor	
COMPLIANCE			
Certifications		CA Rule 21 (UL 1741-SA), UL 62109-1, IEEE 1547:2018 (UL 1741-SB), FCC Part 15 Class B, ICES-0003 Class B, CAN / CSA-C22.2 NO. 107.1-01 This product is UL Listed as PV Rapid Shutdown Equipment and conforms with NEC 2014, NEC 2017, and NEC 2020 section 690.12 and C22.1-2018 Rule 64-218 Rapid Shutdown of PV Systems, for AC and DC conductors, when installed according to manufacturer's instructions.	

(1) Pairing PV modules with wattage above the limit may result in additional clipping losses. See the compatibility calculator at <https://link.enphase.com/module-compatibility>. (2) Nominal voltage range can be extended beyond nominal if required by the utility. (3) Limits may vary. Refer to local requirements to define the number of microinverters per branch in your area.

# IQ Battery 10C

The IQ Battery 10C all-in-one AC-coupled system is compact, powerful, reliable, and safe. It has a total usable capacity<sup>1</sup> of 10.0 kWh and includes four embedded, grid-forming microinverters with a 7.08 kVA continuous power rating. It provides backup capability, and installers can quickly design the right system size to meet the customer's needs.



Key specifications	IQBATTERY-10C-1P-NA
Rated (continuous) output power	7.08 kVA <sup>1</sup>
Rated output current (@240 V <sub>L-L</sub> AC~)	29.5 A <sup>1</sup>
Rated neutral current (@120 V <sub>L-N</sub> AC~)	24 A <sup>1</sup>
Interconnection	Single-phase
Nominal voltage	120/240 VAC~
Nominal frequency	60 Hz
Usable capacity	10.0 kWh <sup>1</sup>
Ambient operating temperature range (charging) <sup>1</sup>	-20°C to 50°C (-4°F to 122°F) Non-condensing
Ambient operating temperature range (discharging) <sup>1</sup>	-20°C to 55°C (-4°F to 131°F) Non-condensing
Chemistry	Lithium iron phosphate (LFP)
Mounting	Wall-mount or pedestal-mount (sold separately)

## Powerful

- Provides 56 A peak current for 3 seconds
- Includes four embedded IQ8B Microinverters
- Most powerful microinverter with up to 2.1 kVA continuous power

## Reliable

- Cools passively with no moving parts or fans
- Uses wired communication for fast and consistent connection
- Updates software and firmware remotely

## Simple

- Fully integrated AC Battery system with neutral forming capabilities
- Installs and commissions easily
- Offers homeowners remote monitoring and control from the Enphase App
- Field replaceable components

## Safe

- Evaluated to UL 9540A, the highest industry standard for battery safety
- Uses LFP chemistry for maximum safety and longevity

### Product dimensions

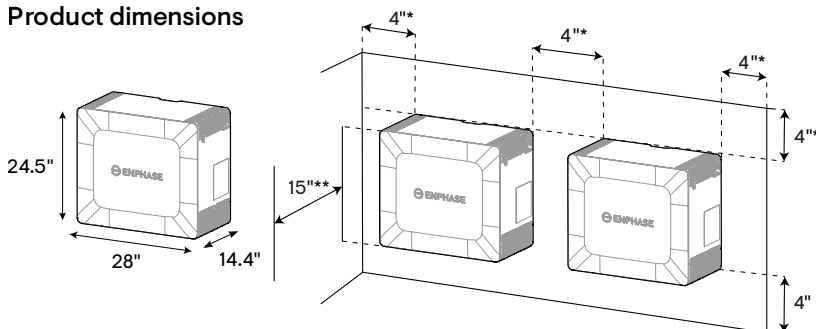

\* The 4" clearances on the sides and the top are per the UL 9540A evaluation, Enphase recommends 8" for ease of service.  
 \*\* Follow the local and national regulations while planning. A 15" clearance in the front is recommended for ease of service.

<sup>1</sup> Refer to the following page for more details.

Product details	Order code: IQBATTERY-10C-1P-NA
Name	IQ Battery 10C
Description	The IQ Battery 10C system with two 5 kWh battery units having integrated IQ Microinverters (SKU: IQ8BL, IQ8BN) with a battery management system (BMS) as part of IQBL Microinverters.
Limited warranty	
IQ Battery 10C unit	60% capacity, up to 15 years, or 6,000 cycles <sup>2</sup>
Output (AC~)	@240 VAC <sup>3</sup>
Rated (continuous) output power	7.08 kVA <sup>4</sup>
Nominal voltage/range	240/211–264 VAC~
Nominal frequency/range	60/57–63 Hz
Rated output current (@240 V <sub>L-L</sub> AC~)	29.5 A <sup>4</sup>
Rated neutral current (@240 V <sub>L-N</sub> AC~)	24 A <sup>5</sup>
Peak output current (@240 V <sub>L-L</sub> AC~)	56 A (three seconds), 44.8 A (ten seconds)
Power Start capability	Up to 90 A LRA <sup>6</sup>
Power factor (adjustable)	0.85 leading ... 0.85 lagging
Maximum conductor size supported	3 AWG
Overcurrent protection device (OCPD)	40 A OCPD, requires a minimum of 8 AWG for one IQ Battery 10C or 80 A OCPD, requires a minimum of 4 AWG for two or more IQ Battery 10C <sup>7</sup>
Interconnection	Single-phase
AC round-trip efficiency <sup>8</sup>	90%
Battery	
Total capacity	10.0 kWh
Usable capacity <sup>9</sup>	10.0 kWh
DC round-trip efficiency	96%
Nominal DC voltage	76.8 V
Maximum DC voltage	86.4 V
Ambient operating temperature range (charging) <sup>10</sup>	–20°C to 50°C (–4°F to 122°F) non-condensing
Ambient operating temperature range (discharging) <sup>11</sup>	–20°C to 55°C (–4°F to 131°F) non-condensing
Optimum operating temperature range	0°C to 30°C (32°F to 86°F) <sup>12</sup>
Chemistry	Lithium iron phosphate (LFP)

<sup>2</sup> Whichever occurs first. Restrictions apply.

<sup>3</sup> Supported in both grid-connected and backup/off-grid operations.

<sup>4</sup> 7.08 kVA, 29.5 A for the balanced 240 V<sub>L-L</sub> loads.

<sup>5</sup> A maximum of 24 A, 120 V<sub>L-N</sub> unbalanced loads can be supported along with 5.5 A, 240 V<sub>L-L</sub> loads.

<sup>6</sup> Power Start capability may vary.

<sup>7</sup> More than two IQ Battery 10C on a 4 AWG circuit protected by 80 A OCPD requires setting Power Control System: IQ Battery Oversubscription.

<sup>8</sup> AC to the battery to AC at 50% power rating.

<sup>9</sup> The battery's usable capacity supports loads, and turns PV on (when off-grid), in normal daily operation. The usable capacity includes a safety-critical limit of 2% that safeguards the customer's asset in case of a long-duration grid outage. An additional 3% capacity is maintained for battery electronic sustenance at night. Refer to [http://link.enphase.com/iqbattery\\_usable\\_capacity\\_en\\_na](http://link.enphase.com/iqbattery_usable_capacity_en_na) for more information.

<sup>10</sup> A reduction in charging power occurs at temperatures below 15°C and above 45°C.

<sup>11</sup> A reduction in discharging power occurs at temperatures below 0°C and above 50°C.

<sup>12</sup> Keeping the battery in this temperature range maximizes the battery life.

Mechanical data	
Dimensions (H × W × D)	621 mm × 708 mm × 365 mm (24.5 in × 28 in × 14.4 in)
Maximum lifting weight	57 kg (125 lb)
Total installed weight for	144 kg (317 lb)
Enclosure	Outdoor-NEMA 3R
Cooling	Natural convection
Altitude <sup>13</sup>	Up to 3,000 meters (9,842 feet)
Mounting	Wall-mount or pedestal-mount (sold separately)

Features and compliance	
Compatibility	Compatible with IQ and M Series Microinverters, IQ Meter Collar, IQ Combiner 6C, and IQ Gateway for grid-tied and backup operations.
Communication	Wired control communication
Services	Backup, Self-Consumption, TOU, and NEM integrity
Monitoring	Enphase Installer Platform and Enphase App monitoring options; API integration
Compliance	CA Rule 21 (UL 1741-SA), IEEE 1547:2018 (UL 1741-SB, 3rd Ed.) CAN/CSA C22.2 No. 107.1-16 UL 9540 <sup>14</sup> , UL 9540A <sup>15</sup> , UN 38.3, UL 1998, UL 991, NEMA Type 3R, AC156 EMI: 47 CFR, Part 15, Class B, ICES 003 Cell module: UL 1973, UN 38.3 Inverters: UL 62109-1, IEC 62109-2

### What's in the box (order code: IQBATTERY-10C-1P-NA)

There are a total of three boxes; two boxes contain the 5.0 kWh battery units and the third box contains the IQ Battery 10C cover kit.

#### 5.0 kWh battery unit (B05-C01-US00-1-3)

Battery units	Two 5.0 kWh battery units of IQ Battery 10C
Mounting bracket	Two mounting brackets for mounting the batteries on the wall
Seismic screws	Four seismic screws for securing the battery unit on the mounting bracket
Mounting bracket fasteners	Twelve M8 hexagonal Phillips screws with washers for mounting second wall bracket on preinstalled battery unit
Drill template	Two drill templates to mark drilling points and conduit entry locations on the wall

#### IQ Battery 10C cover kit (B10C-NC-0708-O)

Cover	One cover for IQ Battery 10C
Interconnect power cable	One interconnect power cable assembly for internally connecting two battery units of IQ Battery 10C
Interconnect control cable	One interconnect control cable assembly for internally connecting two battery units of IQ Battery 10C having one preinstalled control connector (without resistor) at one end
Control connector with resistor	One spare control connector with resistor for control wiring
Raceway adapter	Two raceway adapters for routing cables internally between two battery units
Cable holder	Two cable holders for cable management in wiring compartments

<sup>13</sup> Refer to the data sheet for all components used with the IQ Battery 10C to determine the maximum altitude. For example, the IQ Battery 10C has a maximum altitude limit of 3,000 meters, while the IQ Meter Collar has a limit of 2,500 meters. When used together, the maximum altitude is restricted to 2,500 meters

<sup>14</sup> Following local standards, choose a non-habitable indoor location (like a 2-car garage) or an outdoor location where the ambient temperature and humidity are within -20°C to 55°C (-4°F to 131°F) and 5% to 95% RH, non-condensing. Avoid direct sunlight to ensure the temperature stays in the optimal operating range. This ensures charging and discharging currents are not de-rated due to temperature.

<sup>15</sup> Evaluated to UL 9540A for thermal runaway fire propagation and reduced separation distance as required in 2021 IRC R328.3.1, 2021 IFC 1207.1.5, and 2023 NFPA 855 15.3.1 and 9.1.5. Follow all installation instructions and local codes and requirements of the Authority Having Jurisdiction (AHJ) when installing the Enphase Energy System.

**What's in the box (order code: IQBATTERY-10C-1P-NA)**

Conduit covers	One left-side and one right-side conduit cover to close unused conduit openings
Quick install guide (QIG)	QIG for IQ Battery unit installation instructions

**Optional accessories and replacement parts**

IQ8BL-RMA	IQ8BL Microinverter for field replacement
IQ8BN-RMA	IQ8BN Microinverter for field replacement
B05-C01-US00-1-3-RMA	IQ Battery 10C 5.0 kWh battery unit for field replacement
B10C-CX-0709-O	IQ Battery 10C cover for field replacement
B05C-WB-0662-O	IQ Battery 10C wall bracket for field replacement
B10C-PI-0550-O	IQ Battery 10C Pedestal Mount
B05C-LH-0180-O	IQ Battery 10C Lifting Handles. Includes one left-side and one right-side lifting handle
B05C-ACFB-0138-O	IQ Battery 10C AC filter board for field replacement
B05C-NCANB-068-O	IQ Battery 10C control communication board for field replacement
B05C-CS-0161-O	IQ Battery 10C control switch for field replacement
B05C-NLTB-051-O	IQ Battery 10C live and neutral terminal block for field replacement
B05C-NGTB-051-O	IQ Battery 10C ground terminal block for field replacement
B05C-NJTB-027-O	IQ Battery 10C jumper for the terminal block for field replacement
B05C-NETB-049-O	IQ Battery 10C end stop and end cap of terminal block for field replacement
B10C-PIC-0350-O	IQ Battery 10C Interconnect power cable for field replacement
B10C-CIC-0300-O	IQ Battery 10C Interconnect control cable for field replacement
B05C-CP-031-O	IQ Battery 10C conduit plug (large) for field replacement
B05C-CP-026-O	IQ Battery 10C conduit plug (small) for field replacement
B05C-CH-0132-O	IQ Battery 10C cable holder for field replacement
B10C-RA-050-O	IQ Battery 10C raceway adapter for field replacement
B05C-CC-090-O	IQ Battery 10C conduit cover for field replacement
B05C-WC-0620-O	IQ Battery 10C wiring cover for field replacement
B05C-CAT-0100-O	IQ Battery 10C internal cables to connect AC filter board and terminal blocks

# Components of the Enphase Energy System



## **IQ Microinverters**

IQ Series Microinverters pack more power into less space than other rooftop solar systems and make rooftop solar more productive, reliable, smart, and safe.



## **IQ Combiner 6C**

IQ Combiner 6C consolidates interconnection equipment into a single enclosure and streamlines IQ Series Microinverters and IQ Battery 10C installation by providing a consistent, pre-wired solution for residential applications.

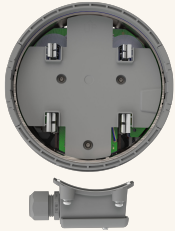

## **IQ Meter Collar**

IQ Meter Collar enables full home backup with IQ Battery 10C, Enphase PV, and IQ Combiner 6C.



## **IQ Battery 10C accessories**

IQ Battery 10C Lifting Handles are reusable and ease the installation process. The IQ Battery 10C Pedestal Mount enables floor mounting of the IQ Battery 10C.

# Revision history

Revision	Date	Description
DSH-00565-4.0	May 2025	<ul style="list-style-type: none"><li>• Updated the peak current.</li><li>• Updated the discharging power temperature range.</li><li>• Added the footnote in the altitude data.</li><li>• Two additional SKUs were added to "Optional accessories and replacement parts."</li><li>• Updated the clearance dimensions from 6" to 4" in the product dimensions image.</li></ul>
DSH-00565-3.0	March 2025	Editorial updates.
DSH-00565-2.0	February 2025	Updated the specifications for order code details.
DSH-00565-1.0	November 2024	Preliminary release.

# HD HYUNDAI SOLAR MODULE

## NF(BK) Series

### Premium N-Type TOPCon Module

HiS-T430NF(BK) | HiS-T435NF(BK) | HiS-T440NF(BK)

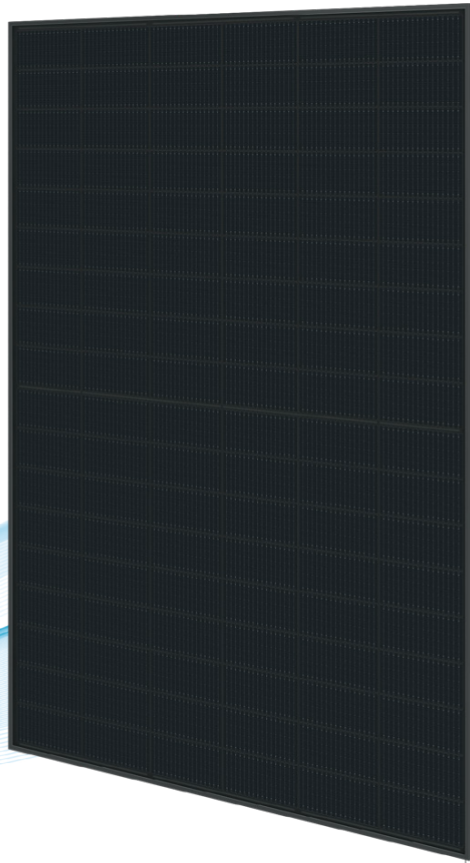

22.53%  
High Efficiency



High-End  
TOPCon  
Technology



Higher  
Bifaciality



Long-Term  
Reliability



For Residential  
(Full Black Design)

#### HD Hyundai's Warranty Provisions

**25**  
YEARS

- 25-Year Product Warranty
- Materials and workmanship

**30**  
YEARS

- 30-Year Performance Warranty
- First year degradation: 1%
- Linear warranty after initial year: with 0.4%p annual degradation, 87.4% is guaranteed up to 30years

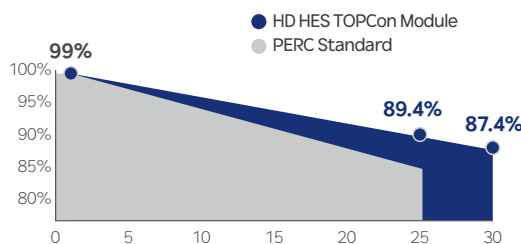

\*Refer to HD HES standard warranty for details.

#### Certification



- UL 61215 / UL 61730 / IEC 61215 / IEC 61730 Certified
- ISO 9001 : Quality management systems
- ISO 14001 : Environmental management systems
- ISO 45001 : Occupational health and safety management systems

## Electrical Characteristics

HiS-TxxxNF(BK)		HiS-T430NF(BK)		HiS-T435NF(BK)		HiS-T440NF(BK)	
Item	Unit	BNPI		BNPI		BNPI	
Nominal output (Pmax)	W	430	477	435	482	440	487
Open circuit voltage (Voc)	V	39.49	39.64	39.69	39.84	39.90	40.05
Short circuit current (Isc)	A	13.83	15.32	13.91	15.41	14.06	15.58
Voltage at Pmax (Vmpp)	V	32.51	32.70	32.74	32.87	32.82	32.95
Current at Pmax (Impp)	A	13.23	14.59	13.29	14.67	13.41	14.79
Module efficiency	%	22.02		22.28		22.53	
Power Class Sorting	W	0 ~ +5					
Temperature coefficient of Pmax	%/K	-0.290					
Temperature coefficient of Voc	%/K	-0.250					
Temperature coefficient of Isc	%/K	0.043					
Bifaciality	%	80±5					

\*STC : Irradiance 1,000 W/m<sup>2</sup>, cell temperature 25°C, AM=1.5 / Test uncertainty for Pmax ±3%; Isc; Voc ±5%  
 \*\*The electrical properties of BNPI are measured under the irradiance corresponding to 1000 W/m<sup>2</sup> on the module front and 135 W/m<sup>2</sup> on the module rear.

Additional Power Gain from rear side						
Pmpp gain	Pmpp[W]	Vmpp[V]	Impp[A]	Voc[V]	Isc[A]	
5%	462	32.82	14.08	39.90	14.77	
15%	506	32.82	15.42	39.90	16.17	
25%	550	32.82	16.76	39.90	17.58	

\*Electrical characteristics with different rear power gain (reference to 440W)

## Mechanical Characteristics

Dimensions	1,722mm (L) x 1,134mm (W) x 30mm (H) (67.8in x 44.6in x 1.2in)
Weight	24.3 kg (53.57 lbs)
Solar Cells	N-Type TOPCon, 108 (6x18) monocrystalline 16BB half-cut bifacial cells
Output Cables	Cable : (+)1,200mm(47.2in), (-)1,200mm(47.2in) / Customized length available Connector : Stäubli MC4 genuine Connector / IP68
Junction Box	3-part, 3 bypass diodes, IP68 rated
Construction	Front : 2.0mm(0.08in) semi-tempered solar glass with high transmittance and anti-reflective coating Rear : 2.0mm(0.08in) semi-tempered solar glass
Frame	Anodized aluminum alloy

## Shipping Configurations

Container Size (HC)	40'	Modules Per Pallet (pcs)	36
Pallets Per Container	22	Modules Per Container (pcs)	792

## Module Diagram (unit : mm)

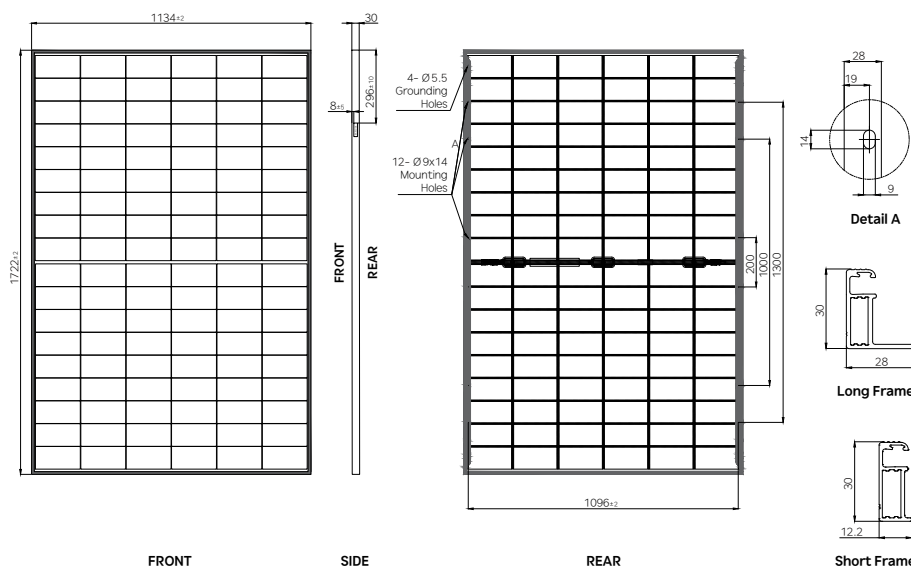

## Installation Safety Guide

- Only qualified personnel should install or perform maintenance.
- Be aware of dangerous high DC voltage.
- Do not handle or install modules when they are wet.

Nominal Module Operation Temperature	41°C ± 2°C
Operating Temperature	-40°C~+85°C
Maximum System Voltage	DC 1,500 V
Maximum Reverse Current	30A
Maximum Test Load	Front 5,400Pa Rear 4,500Pa
Fire Performance	Type 29

## I-V Curves (HiS-T440NF(BK))

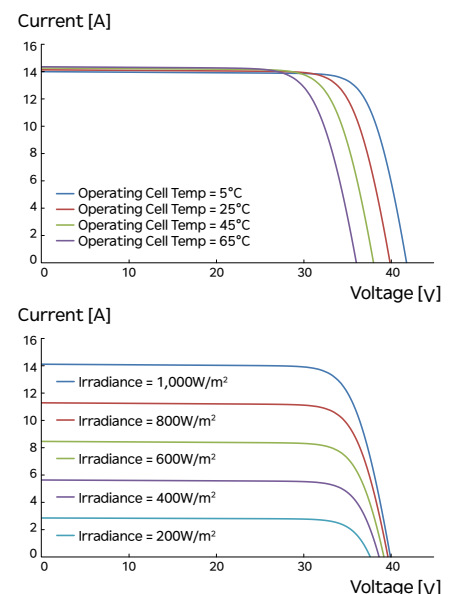

# Q.TRON BLK M-G2+ SERIES



415 - 440 Wp | 108 Cells  
22.5% Maximum Module Efficiency

MODEL Q.TRON BLK M-G2+



## High performance Qcells N-type solar cells

Q.ANTUM NEO Technology with optimized module layout boosts module efficiency up to 22.5%.



## A reliable investment

Inclusive 25-year product warranty and 25-year linear performance warranty<sup>1</sup>.



## Enduring high performance

Long-term yield security with Anti LeTID Technology, Anti PID Technology<sup>2</sup>, Hot-Spot Protect.



## Extreme weather rating

High-tech aluminium alloy frame, certified for high snow (8100 Pa) and wind loads (3600 Pa).



## Innovative all-weather technology

Optimal yields, whatever the weather with excellent low-light and temperature behaviour.



## The most thorough testing programme in the industry

Qcells is the first solar module manufacturer to pass the most comprehensive quality programme in the industry: The new "Quality Controlled PV" of the independent certification institute TÜV Rheinland.

<sup>1</sup> See data sheet on rear for further information.

<sup>2</sup> APT test conditions according to IEC/TS 62804-1:2015, method A (-1500 V, 96 h)

### The ideal solution for:



Rooftop arrays on residential buildings



# Q.TRON BLK M-G2+ SERIES

## Mechanical Specification

Format	67.8 in × 44.6 in × 1.18 in (including frame) (1722 mm × 1134 mm × 30 mm)
Weight	46.7 lbs (21.2 kg)
Front Cover	0.13 in (3.2 mm) thermally pre-stressed glass with anti-reflection technology
Back Cover	Composite film
Frame	Black anodised aluminium
Cell	6 × 18 monocrystalline Q.ANTUM NEO solar half cells
Junction box	2.09-3.98 in × 1.26-2.36 in × 0.59-0.71 in (53-101 mm × 32-60 mm × 15-18 mm), Protection class IP67, with bypass diodes
Cable	4 mm <sup>2</sup> Solar cable; (+) ≥ 68.9 in (1750mm), (-) ≥ 68.9 in (1750mm)
Connector	Stäubli MC4; IP68

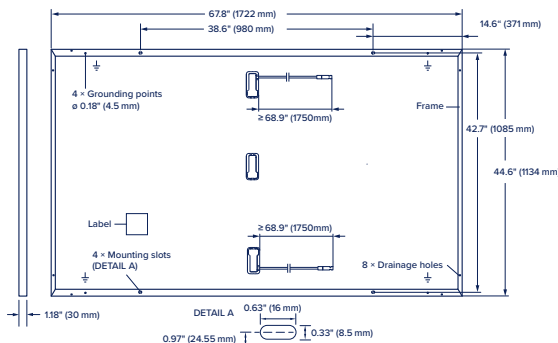

## Electrical Characteristics

POWER CLASS			415	420	425	430	435	440
MINIMUM PERFORMANCE AT STANDARD TEST CONDITIONS, STC <sup>1</sup> (POWER TOLERANCE +5 W/-0 W)								
Minimum	Power at MPP <sup>1</sup>	$P_{MPP}$ [W]	415	420	425	430	435	440
	Short Circuit Current <sup>1</sup>	$I_{SC}$ [A]	13.49	13.58	13.66	13.74	13.82	13.90
	Open Circuit Voltage <sup>1</sup>	$V_{OC}$ [V]	38.47	38.75	39.03	39.32	39.60	39.88
	Current at MPP	$I_{MPP}$ [A]	12.83	12.91	12.98	13.05	13.13	13.20
	Voltage at MPP	$V_{MPP}$ [V]	32.34	32.54	32.74	32.94	33.14	33.33
	Efficiency <sup>1</sup>	$\eta$ [%]	≥21.3	≥21.5	≥21.8	≥22.0	≥22.3	≥22.5
MINIMUM PERFORMANCE AT NORMAL OPERATING CONDITIONS, NMOT <sup>2</sup>								
Minimum	Power at MPP	$P_{MPP}$ [W]	313.7	317.5	321.2	325.0	328.8	332.6
	Short Circuit Current	$I_{SC}$ [A]	10.87	10.94	11.00	11.07	11.14	11.20
	Open Circuit Voltage	$V_{OC}$ [V]	36.50	36.77	37.04	37.31	37.58	37.84
	Current at MPP	$I_{MPP}$ [A]	10.10	10.15	10.21	10.27	10.33	10.38
	Voltage at MPP	$V_{MPP}$ [V]	31.07	31.26	31.46	31.65	31.84	32.03

<sup>1</sup>Measurement tolerances  $P_{MPP} \pm 3\%$ ;  $I_{SC}$ ;  $V_{OC} \pm 5\%$  at STC; 1000 W/m<sup>2</sup>, 25 ± 2 °C, AM 1.5 according to IEC 60904-3 • <sup>2</sup>800 W/m<sup>2</sup>, NMOT, spectrum AM 1.5

## Qcells PERFORMANCE WARRANTY

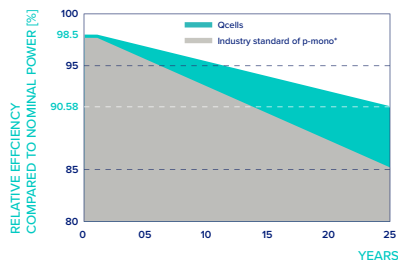

At least 98.5% of nominal power during first year. Thereafter max. 0.33% degradation per year. At least 95.53% of nominal power up to 10 years. At least 90.58% of nominal power up to 25 years.

All data within measurement tolerances. Full warranties in accordance with the warranty terms of the Qcells sales organisation of your respective country.

<sup>\*</sup>Standard terms of guarantee for the 5 PV companies with the highest production capacity in 2021 (February 2021)

## PERFORMANCE AT LOW IRRADIANCE

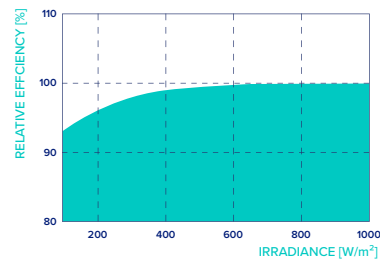

Typical module performance under low irradiance conditions in comparison to STC conditions (25 °C, 1000 W/m<sup>2</sup>).

## TEMPERATURE COEFFICIENTS

Temperature Coefficient of $I_{SC}$	$\alpha$ [%/K]	+0.04	Temperature Coefficient of $V_{OC}$	$\beta$ [%/K]	-0.24
Temperature Coefficient of $P_{MPP}$	$\gamma$ [%/K]	-0.30	Nominal Module Operating Temperature	NMOT [°F]	109 ± 5.4 (43 ± 3 °C)

## Properties for System Design

Maximum System Voltage	$V_{SYS}$ [V]	1000 (IEC)/1000 (UL)	PV module classification	Class II
Maximum Series Fuse Rating	[A DC]	25	Fire Rating based on ANSI/UL 61730	C / TYPE 2
Max. Design Load, Push/Pull <sup>3</sup>	[lbs/ft <sup>2</sup> ]	113 (5400 Pa)/50 (2400 Pa)	Permitted Module Temperature on Continuous Duty	-40 °F up to +185 °F (-40 °C up to +85 °C)
Max. Test Load, Push/Pull <sup>3</sup>	[lbs/ft <sup>2</sup> ]	169 (8100 Pa)/75 (3600 Pa)		

<sup>3</sup> See Installation Manual

## Qualifications and Certificates

Quality Controlled PV -  
TÜV Rheinland;  
IEC 61215:2016;  
IEC 61730:2016.  
This data sheet complies  
with DIN EN 50380.



<sup>\*</sup>UL and California Energy Commission (CEC) listings pending



Qcells pursues minimizing paper output in consideration of the global environment.

Note: Installation instructions must be followed. Contact our technical service for further information on approved installation of this product.  
Hanwha Q CELLS America Inc. 400 Spectrum Center Drive, Suite 1400, Irvine, CA 92618, USA | TEL +1 949 748 59 96 | EMAIL hqc-inquiry@qcells.com | WEB www.qcells.com

qcells